

INSTRUCTION BOOK

FOR

Johnson

Outboard Motors



Edition K

FOR ALL MOTORS EXCEPT THOSE
HAVING ELECTRIC STARTERS

JOHNSON MOTOR COMPANY
WAUKEGAN • ILLINOIS

WARRANTY

All of the Johnson Motor Company's products (except racing motors and parts of racing motors) are warranted to be free from defects in material and workmanship under normal use and service for a period of 90 days after date of purchase.

The Johnson Motor Company guarantee, in accordance with its Warranty, will REPAIR or REPLACE motors or parts under the following conditions:

Regular claim forms are provided all our dealers, service stations and distributors. NO PART WILL BE REPLACED UNLESS THIS FORM IS USED.

All material—motors or parts—should be returned to your nearest distributor or service station TRANSPORTATION CHARGES PREPAID. See pages 34 and 35 for list of distributors and service stations.

The Johnson Motor Company, Waukegan, Illinois, will make *final decision* on material—motors or parts—whether or not defective and subject to credit replacement through distributor.

No product of the Johnson Motor Company will be accepted for credit, replacement or repair at the factory, Waukegan, Illinois, unless such material is returned through one of our authorized distributors or service stations using regular form.

REMEMBER—ALWAYS request a claim form and properly fill it in before returning any material to our distributor or service station.

**BUY YOUR REPAIR PARTS
THRU YOUR LOCAL DEALER**

SEE YOUR LOCAL DEALER FOR ALL ADJUSTMENTS AND REPAIRS.

DON'T RETURN ANY PARTS TO THE FACTORY—They must go through your distributor or service station. See pages 34 - 35.

Johnson

Outboard Motors

MODELS J-A-K-KR-S-SR-P-PR-V-VR-XR

*Information for the
Owner*



Edition K

**BUY YOUR REPAIR PARTS
THRU YOUR LOCAL DEALER**

**JOHNSON MOTOR COMPANY
WAUKEGAN ILLINOIS**

JOHNSON SERVICE

What it Means to the Owner

It has always been the belief of the Johnson Motor Company that a sale does not complete the transaction between ourselves and the buyer. Rather it establishes a new obligation on our part—an obligation to see that his motor gives him service.

For this reason we have installed a system of nation-wide service to Johnson Motor Owners to take care of all Johnson Motor needs in a manner that is speedy, economical and satisfactory.

The first step in the structure of this system is the residential dealer who is supplied with first aid parts, enabling him to supply repair parts for emergencies and minor repairs. The second step in the structure is the authorized dealer, who will at least carry first aid parts or carry a larger stock of the emergency repair parts. Many of these authorized dealers may also be service stations and carry a larger stock of parts and also maintain an up-to-date repair and service department.

When in need of more extensive repairs or service, or a complete overhauling of the motor, the owner can send his motor to one of the authorized service stations located in the section nearest to the point motor is maintained.

These service stations carry a complete stock of parts for all types of Johnson motors, as well as up-to-date equipment and tools specified by the Johnson Motor Company to insure satisfactory repairs by skilled mechanics.

From the very beginning Service to Owners has been one of the chief interests of the Johnson Motor Company. We have maintained a complete service department here in Waukegan to answer the needs of our customers. We have provided a free training course for service men that they may be better equipped to take care of the problems of our owners throughout the country.

With this policy of service ever uppermost in our minds, we have built an organization that consists of a nation-wide network of Johnson Service Stations. A complete list of these stations is given on pages 34 and 35 of this book.

So now, wherever you live, or wherever you go, you will find within easy reach, a Johnson Service Station, that is prompt and business-like in its work, fair in its charges, and sincerely eager to do a good and thorough job at all times.

Our constant effort is to relieve you of every detail in the care of your Johnson Motor—to help you get hour after hour and mile after mile of satisfactory enjoyable water motoring.

That is the purpose for which Johnson Motors were built. That is the true meaning of Johnson Service.

IMPORTANT

In order that you obtain the maximum service from your Johnson Motor, these simple instructions must be followed:

1. Purchase a new clean gasoline can in which to mix the oil and the gasoline. Also procure a pint measure and a funnel with small pieces of brass gauze soldered in the bottom of it.
2. Mix thoroughly in the can, the proper amount of oil as directed under "oiling," with good grade of clean gasoline. (Don't guess—measure it.) Don't mix fuel in motor tanks except in emergency.
3. Always clamp the motor securely to the stern of the boat before starting it. Otherwise, motor may be lost overboard.
4. Follow starting instructions on the tank or instruction card. After motor is started and running full speed, familiarize yourself thoroughly with the action of the needle valve by turning it backward or forward, carefully noting results. The needle valve should be set at a point where motor runs fastest.
5. Refill the gear case with grease as recommended at least once each week if motor is used every day. *This is very important.* If motor is to be laid away for any length of time drain gear case and refill with fresh grease.
6. It is not necessary to stop the motor when making a landing unless the propeller is touching bottom. Simply throttle motor down to slow speed when approaching landing or wharf and gently turn the motor from one side to other and boat can be slowly moved along side the landing place and held in that position without stopping motor. *This does not apply to motors with underwater exhaust, except Models A & K-50 - 65.*
7. When backing away from landing place, be sure the water is deep enough and not obstructed, otherwise, the motor will be damaged and possibly broken by backing it into something solid. Remember the motor does not tip up when running backward. Motors with underwater exhaust cannot be reversed except Models A & K-50-65.
8. Read this book carefully, follow the instructions and the motor will give you the best of service.

JOHNSON MOTOR COMPANY

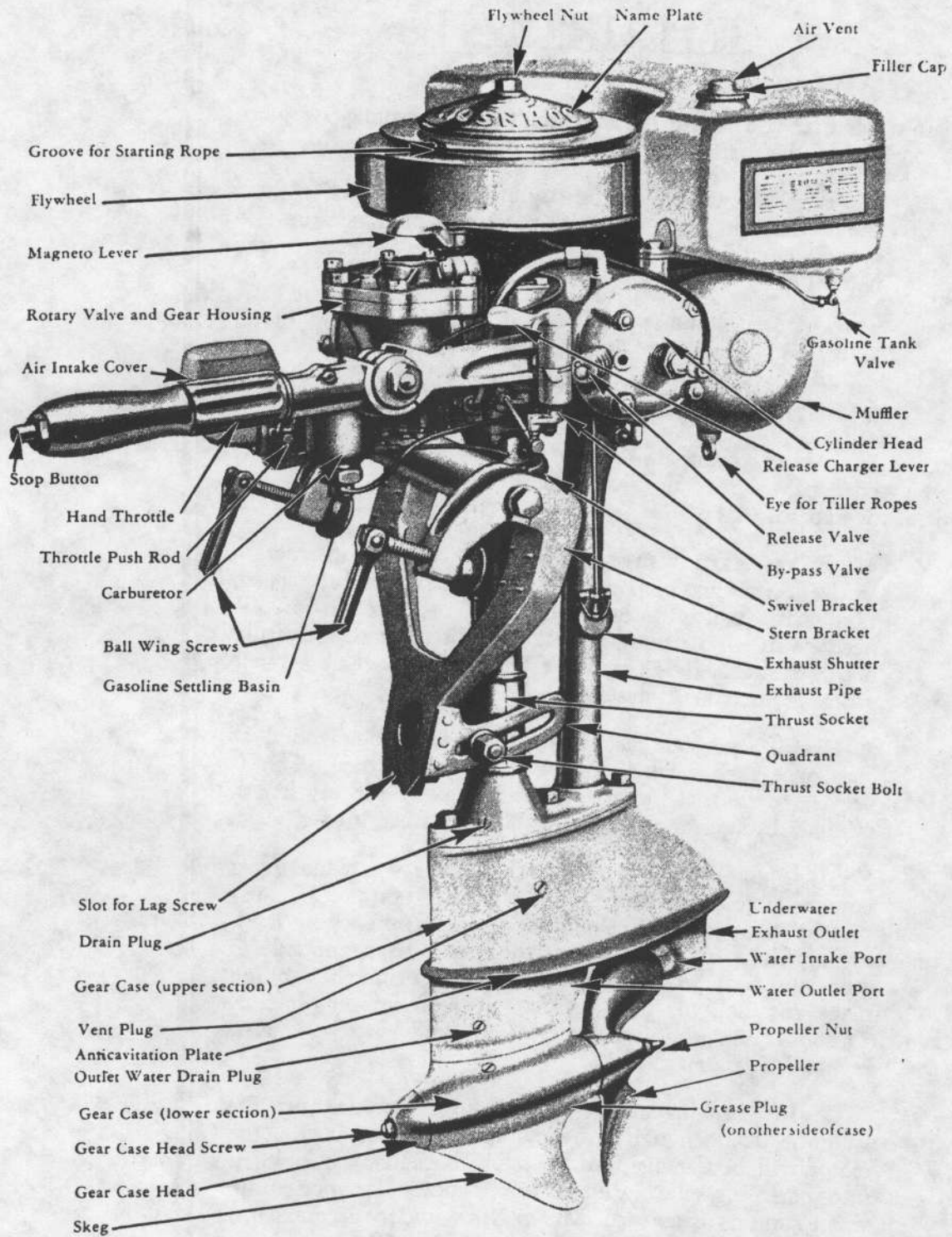

Fig. 1. Sea Horse 16, Model S-45

BOOK OF INSTRUCTIONS

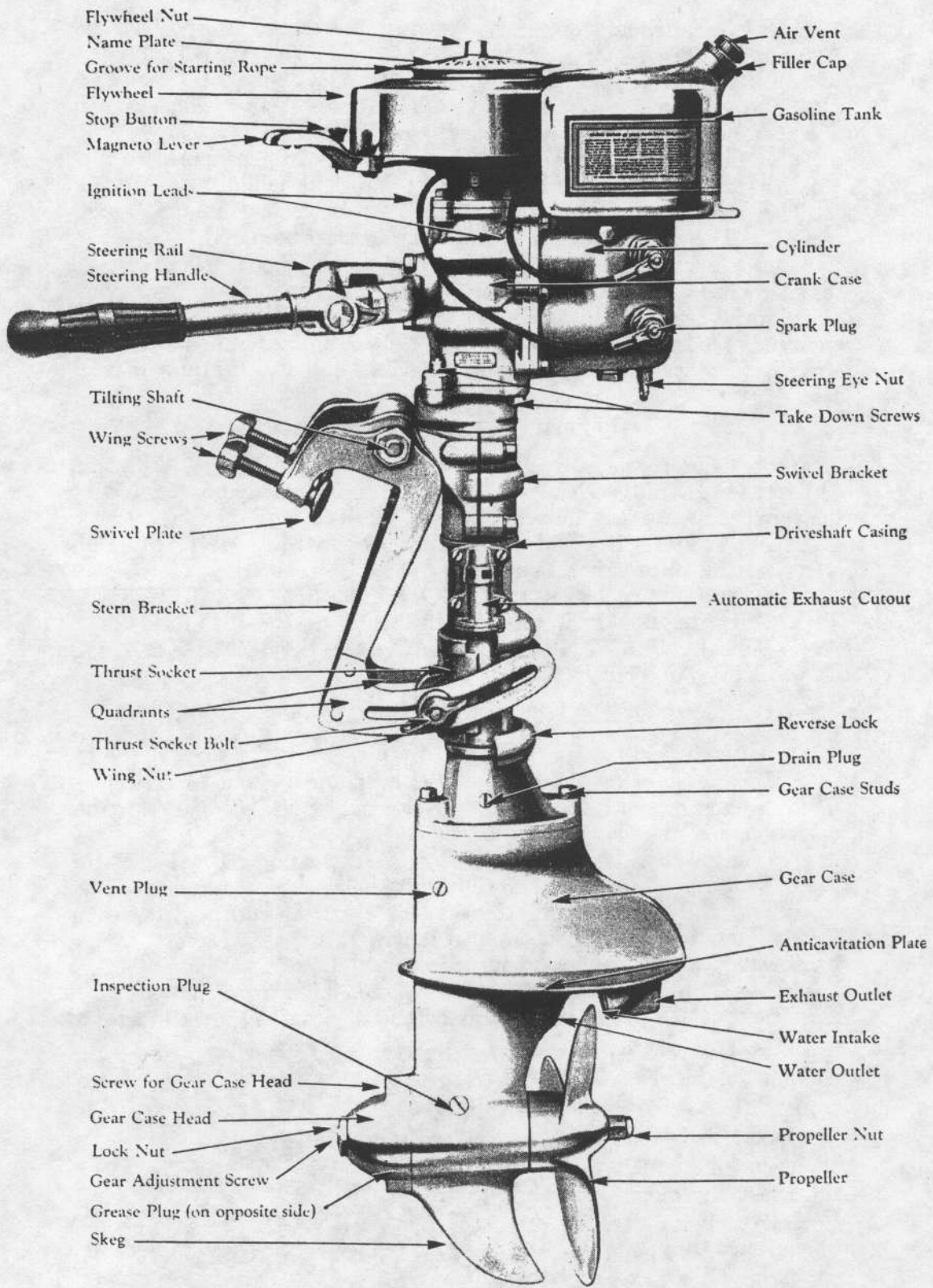

Fig. 2. Sea Horse 12, Model K-50

General Description

The Johnson Motors are of the two cycle, three and two port Rotary Valve type. Sea Horse "16", "24", "32" and "50", are all equipped with Rotary Valve, gear driven (See Page 25). This Sea Horse "4", "12" and A & K-65 are equipped with a Rotary Valve which is part of the crankshaft, eliminating Rotary gears.

The ports and combustion chambers are accurately machined to provide perfect distribution of the fuel charge to both cylinders.

The pistons and cylinders are of the best material, ground to a perfect fit. There are two piston rings above the piston pin.

The crankshaft, piston pins, drive shaft and propeller shaft are all case-hardened and ground to a high polish, these turning in hard phosphor bronze bearings, give long life to the motor if lubricated as recommended. Models S, SR, P-50, PR-50, V, VR and XR, including "65" series have roller bearings in connecting rods and ball bearings in gear case.

MOTOR SERIAL NUMBER

Your Johnson motor is known to the factory by its MODEL and SERIAL NUMBER ONLY. This number is located on the top of the flywheel or ree-coil starter as shown below. (Fig. 3.)

ALWAYS GIVE MOTOR SERIAL NUMBER AND MODEL when seeking information or ordering parts.

FOR YOUR OWN PROTECTION YOU SHOULD REGISTER THE SERIAL NUMBER OF YOUR MOTOR BY FILLING OUT AND RETURNING THE RECORD CARD, ENCLOSED IN THE TOOL KIT, TO THE FACTORY.

ATTACHING TO BOAT OR CANOE

Square Stern Type

Place the motor on the stern of the boat and tighten the clamp as tightly as possible with the fingers. A wrench is not necessary for this operation, but the clamp must be tight.

Adjust the drive shaft casing to a vertical position by means of the lower wing nut (Fig. 4). Try tilting the motor to see that it operates freely and will not strike anything when tilted; also turn motor completely around to see that nothing strikes the boat. Motors having underwater exhaust cannot be turned completely around, except A and K-50-65 models. If the stern is too high, cut it down so that the anti-cavitation plate is about 1½" below bottom of boat, as shown in Fig. 6.

If the boat has an exceptionally thick stern or transom, chisel it out, where the clamps go, to a thickness of about 1¼"; otherwise the motor may not tilt enough.

The motor should be placed on the boat so that the drive shaft is in a vertical position when the boat is under way.



Fig. 3. Name plate, showing motor serial number

EXTRA DEEP BOATS

For deep sterns that cannot be cut down or boats with high free-board, a 6" longer driveshaft may be obtained at a slight additional cost. (Not furnished for single cylinder, OA-55 or OK-55 motors).

Lag Screw

The use of the lag screw as shown in Fig. 5 is not absolutely necessary, but will be found to be of a decided advantage when the motor is continually used on the same boat. The lag screw will prevent the motor from slipping on the stern, if for any reason the clamps are not properly tightened or if the stern board is not in first class condition.

To use the lag screw, place it between the jaws on the bottom of the stern clamp, when motor is properly clamped to boat, and tap it gently with a hammer. Drill a small hole in stern at this point and then screw in the lag screw until it is within 1/16" of the bracket.

The lag screw need not be removed, once it has been placed in the proper position. Simply slip the slot in the bracket under the head of the screw when putting the motor on the boat.

Canoe or Pointed Stern Type (Sea Horse "Single" "3" and "4" only)

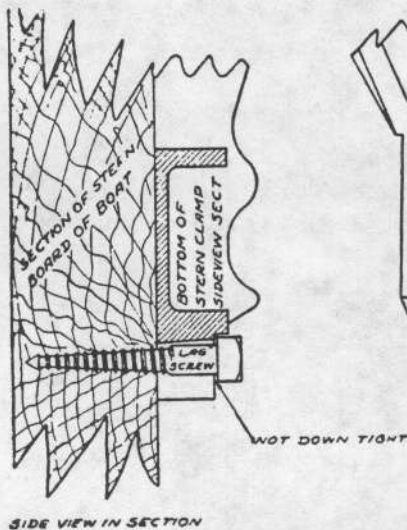

Fig. 5. Lag screw installation

bore a 1/4" hole. Now insert the bolt, furnished with the attachment, through the sheer strip from the inside of the canoe and bolt the left side of the casting down first.

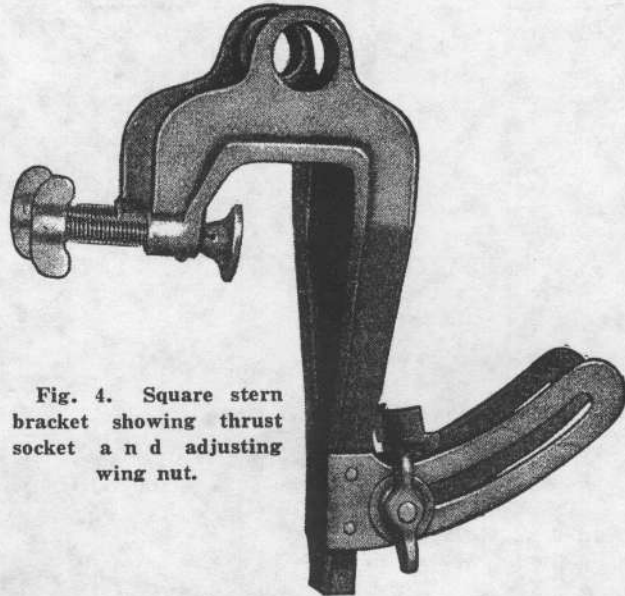

Fig. 4. Square stern bracket showing thrust socket and adjusting wing nut.

To mount the motor on a canoe or pointed stern boat proceed as follows: At a point where the canoe or boat is ten inches wide over all, draw a line across the deck, as illustrated in Fig. 8, at right angles to a line through center of the canoe; the distance CA should then be equal to the distance AE. On the left side of the deck, facing the stern, at a point where the line AB crosses the center of the inside sheer strip at E,

After checking to see that the center line of the tubing is directly over the line CE and while in this position, bore two $\frac{1}{4}$ " holes in the right side of the sheer strip through the slotted holes in that side of the casting. This will insure the deck plate always being on straight.

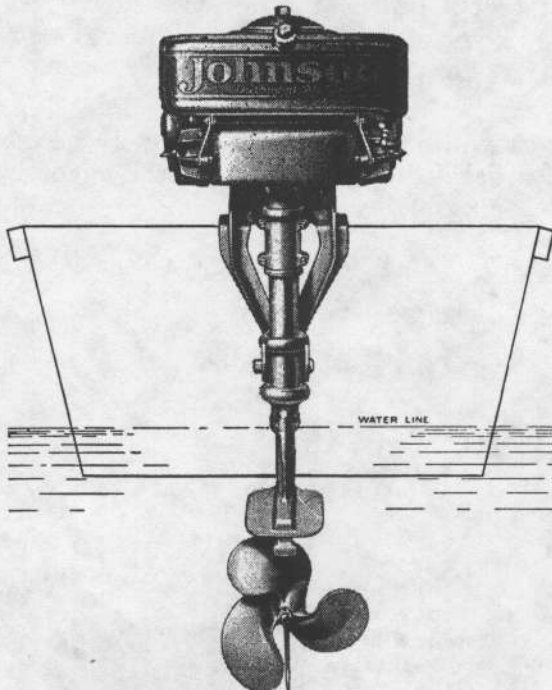

Fig. 6. Showing proper depth of motor in water

in a vertical position when the canoe is under way. Be sure the cap-screw, holding thrust arm, is tightened securely, as well as the clamp-screw in top of thrust arm.

Before starting the motor, make sure that the motor will turn completely around to any position without striking the canoe. If the motor is too far away from the hull of the canoe it may be shifted in by loosening the three deck bolts and moving the deck plate back the depth of the three slotted holes in the bracket.

The canoe attachment is interchangeable with the square stern brace

Insert the two bolts through the holes from the inside of the canoe, place washers on the bolts and then tighten all three nuts securely. Place the motor in position by slipping the swivel bracket over tubing and then tighten the clamp just tight enough to allow the motor to tilt freely. Place the retaining collar on the end of tubing and clamp it securely. Adjust the thrust arm so that the the drive shaft is

in a vertical position when the canoe is under way. Be sure the cap-screw, holding thrust arm, is tightened securely, as well as the clamp-screw in top of thrust arm.

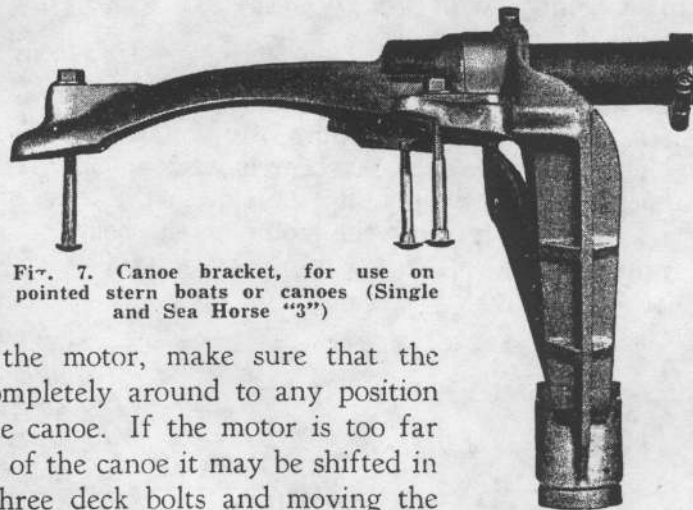

Fig. 7. Canoe bracket, for use on pointed stern boats or canoes (Single and Sea Horse "3")

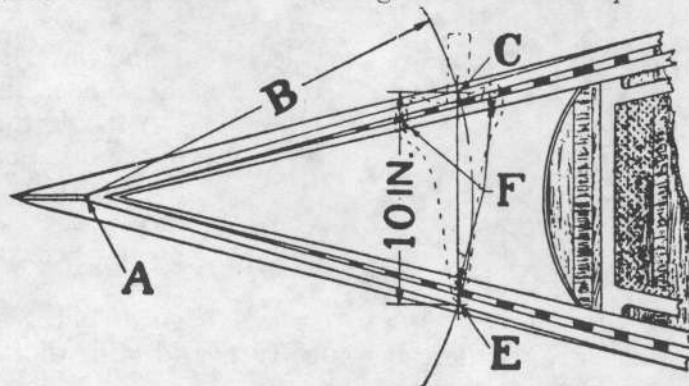

Fig. 8. Canoe bracket installation

BOOK OF INSTRUCTIONS

ket. It is used on the Light Single, Light Twin, Sea Horse "Single," "3", "4", J-65 and A-65 only.

CORRECT HEIGHT OF STERNS

Motor Name	Model	Stern Heights
Light Single	J-25	14 inches
Light Twin	A-35	14 inches
Light Twin	OA-55-60-65	14 inches
Standard	OK-55-60	15 inches
Standard Twin	K-40	15 inches
Big Twin	P-40	16 inches
Giant Twin	TR-40	16 inches
Sea Horse Single	J-25-65	14 inches
Sea Horse "3"	A-45	14 inches
Sea Horse "4"	A-50-65	14 inches
Sea Horse "10"	K-45	15 inches
Sea Horse "12"	K-50-65	15 inches
Sea Horse "14"	P-45	16 inches
Sea Horse "16"	S-45, SE-50, S-65	16 inches
Sea Horse "24"	P-50, PE-50, P-65	16 inches
Sea Horse "32"	V-45, VE-50, VA-50 & V-65	16 inches
Sea Horse "16"	SR-45, SR-50 & SR-55	14 inches
Sea Horse "32"	VR-45, VR-50 & VR-55	14 inches
Sea Horse "24"	PR-50 & PR-55	14 inches
Sea Horse "50"	XR-55	14 inches
	SR, PR-60-65	13 $\frac{1}{4}$ ins.

FOR ORDINARY SERVICE, the above table shows the correct height of stern from top to bottom of boat (outside measurement).

FOR HIGH SPEED WORK on light weight boats, the stern should be as high as can be used without causing propeller to cavitate from running too close to surface of water.

On cruisers, large runabouts and boats used in very rough water, the stern should be low enough so the propeller does not come out of the water when riding over the crests of large waves.

NOTE: The above table covers our regular length motors only. We furnish all models (except Sea Horse Single) with six inches longer drive shaft except the Sea Horse "4" and "12" which are only five inches longer.

GASOLINE TANK CAPACITY

Motor Name	Model	Tank Capacity	Motor Name	Model	Tank Capacity
Light Single	J-25	$\frac{1}{2}$ Gal.	Sea Horse "32"	V-45-65	4 Gals.
Light Twin	A-35	6 Pints	Sea Horse "16"	SR-45	2.4 Gals.
Light Twin	OA-55	7 $\frac{1}{4}$ Pints	Sea Horse "32"	VR-45	4 Gals.
Standard Twin	OK-55	1.8 Gals.	Sea Horse "16"	SE-50	2.4 Gals.
Standard Twin	K-40	1 $\frac{1}{2}$ Gals.	Sea Horse "32"	VE-50	4 Gals.
Big Twin	P-40	2 $\frac{1}{2}$ Gals.	Sea Horse "24"	PE-50	2.4 Gals.
Giant Twin	TR-40	4 Gals.	Sea Horse "16"	SR-50	2.4 Gals.
Sea Horse Single	J-25-65	$\frac{1}{2}$ Gal.	Sea Horse "24"	PR-50	2.4 Gals.
Sea Horse "3"	A-45	6 Pints	Sea Horse "32"	VR-50	4 Gals.
Sea Horse "4"	A-50-65	7 Pints	Sea Horse "16"	SR-55-60-65	2.4 Gals.
Sea Horse "10"	K-45	1 $\frac{1}{2}$ Gals.	Sea Horse "24"	PR-55-60-65	2.4 Gals.
Sea Horse "12"	K-50-65	13 Pints	Sea Horse "32"	VR-55	4 Gals.
Sea Horse "14"	P-45	2 $\frac{1}{2}$ Gals.	Sea Horse "50"	XR-55	4 Gals.
Sea Horse "16"	S-45-65	2.4 Gals.			
Sea Horse "24"	P-50-65	2.4 Gals.			
Sea Horse "25"	TR-45	4 Gals.			

MOTOR LUBRICATION

Lubrication is the most important factor in the operation of internal combustion engines. Correct lubrication insures long life and satisfactory performance, whereas incorrect lubrication invariably results in premature wear and unnecessary expense.

The cylinders, pistons, crankshaft and connecting rod bearings are lubricated by mixing the oil with the gasoline.

The following instructions, therefore, should be carefully observed if you wish to get the maximum of service from your motor.

There are two conditions entering into the oiling of Johnson Motors: one for **ORDINARY SERVICE** when the motor is used with the muffler and all equipment on; the other for **HIGH SPEED**, in racing trim, where high speed is desired on light fast boats.

Make sure of the type of motor you have before mixing the oil and gasoline. Then consult the following tables for that particular type:

OILING FOR ORDINARY SERVICE

Use an oil such as Mobiloil Marine Heavy Medium or Mobiloil "A" for ordinary service mixing in the following ratio:

Lt. Single (Sea Horse Single), J-25-65	1/2 pint oil to 1 gallon gas.
Light Twin, A, A-25-35	1/2 pint oil to 1 gallon gas.
Light Twin Model OA-55-60-65	1/2 pint oil to 1 gallon gas.
Standard Twin Model OK-55-60	3/4 pint oil to 1 gallon gas.
Standard Twin Model K-35	1/2 pint oil to 1 gallon gas.
Standard Twin Model K-40	3/4 pint oil to 1 gallon gas.
Big Twin Model P-30	3/4 pint oil to 1 gallon gas.
Big Twin Model P-35	3/4 pint oil to 1 gallon gas.
Big Twin Model P-40	1 pint oil to 1 gallon gas.
Sea Horse "3" Model A-45	1/2 pint oil to 1 gallon gas.
Sea Horse "4" Model A-50-65	1/2 pint oil to 1 gallon gas.
Sea Horse "10" Model K-45	1/2 pint oil to 1 gallon gas.
Sea Horse "12" Model K-50-65	3/4 pint oil to 1 gallon gas.
Sea Horse "14" Model P-45	1 pint oil to 1 gallon gas.
Sea Horse "24" Model P-50-65	1 pint oil to 1 gallon gas.
Aquafllyer "24" Model PA-50	1 pint oil to 1 gallon gas.
Aquafllyer "16" Model SE-50	1 pint oil to 1 gallon gas.
Sea Horse "16" Model S-45-65	1 pint oil to 1 gallon gas.
Sea Horse "24" Model PE-50-65	1 pint oil to 1 gallon gas.
Aquafllyer "16" Model SA-50	1 pint oil to 1 gallon gas.
Sea Horse "25" Model TR-40	1 pint oil to 1 gallon gas.
Sea Horse "32" Model V-45-65	1 pint oil to 1 gallon gas.
Acquafllyer "32" Model VA-50	1 pint oil to 1 gallon gas.
Sea Horse "32" Model VE-50-65	1 pint oil to 1 gallon gas.

OILING FOR HIGH SPEED SERVICE IN RACING TRIM

For the following models for High Speed Service in Racing Trim, use an oil such as Mobiloil Marine Heavy Medium or Mobiloil "A" mixing in the proper proportions as follows:

Lt. Twin Model OA-55-60-65	3/4 pint oil to 1 gallon gas.
Standard Twin Model K-35	1 pint oil to 1 gallon gas.
Big Twin Model P-30	1 1/2 pints oil to 1 gallon gas.
Sea Horse "3" Model A-45	3/4 pint oil to 1 gallon gas.
Sea Horse "14" Model P-45	1 quart oil to 1 gallon gas.

BOOK OF INSTRUCTIONS

For the following models for High Speed Service, we suggest the use of a heavier oil such as Mobiloil Marine Heavy or Mobiloil "B" in the mixtures as listed:

Standard Twin Model K-40	1 $\frac{1}{4}$ pints oil to 1 gallon gas.
Standard Twin Model KR-40	1 $\frac{1}{2}$ pints oil to 1 gallon gas.
Standard Twin Model OK-55-60	1 $\frac{1}{4}$ pints oil to 1 gallon gas.
Sea Horse "12" Model KR-55-65	1 $\frac{1}{2}$ pints oil to 1 gallon gas.
Big Twin Model P-40	1 $\frac{1}{2}$ pints oil to 1 gallon gas.
Big Twin Model PR-40	1 quart oil to 1 gallon gas.
Giant Twin Model TR-40	1 quart oil to 1 gallon gas.
Sea Horse "4" Model A-50-65	$\frac{3}{4}$ pint oil to 1 gallon gas.
Sea Horse "10" Model K-45	1 $\frac{1}{4}$ pints oil to 1 gallon gas.
Sea Horse "12" Model K-50-65	1 $\frac{1}{4}$ pints oil to 1 gallon gas.
Sea Horse "24" Model P-50-65	1 $\frac{1}{2}$ pints oil to 1 gallon gas.
Aquaflyer "24" Model PE-50	1 $\frac{1}{2}$ pints oil to 1 gallon gas.
Sea Horse "24" Model PR-50	1 $\frac{1}{2}$ pints oil to 1 gallon gas.
Sea Horse "16" Model S-45-65	1 $\frac{1}{2}$ pints oil to 1 gallon gas.
Aquaflyer "16" Model SE-50	1 $\frac{1}{2}$ pints oil to 1 gallon gas.
Sea Horse "16" Model SR-45	1 $\frac{1}{2}$ pints oil to 1 gallon gas.
Sea Horse "16" Model SR-50	1 $\frac{1}{2}$ pints oil to 1 gallon gas.
Sea Horse "25" Model TR-40	1 quart oil to 1 gallon gas.
Sea Horse "32" Model V-45-65	1 $\frac{1}{2}$ pints oil to 1 gallon gas.
Aquaflyer "32" Model VE-50	1 $\frac{1}{2}$ pints oil to 1 gallon gas.
Sea Horse "32" Model VR-45	1 $\frac{1}{2}$ pints oil to 1 gallon gas.
Sea Horse "32" Model VR-50	1 $\frac{1}{2}$ pints oil to 1 gallon gas.
Sea Horse "16" Model SR-55-60-65	1 $\frac{1}{2}$ pints oil to 1 gallon gas.
Sea Horse "24" Model PR-55-60-65	1 $\frac{1}{2}$ pints oil to 1 gallon gas.
Sea Horse "32" Model VR-55	1 $\frac{1}{2}$ pints oil to 1 gallon gas.
Sea Horse "50" Model XR-55	1 $\frac{1}{2}$ pints oil to 1 gallon gas.

Mobiloil Marine Heavy or Mobiloil "B" should not be used in ORDINARY SERVICE. Neither should the proportion of oil and fuel recommended for racing be used in ORDINARY SERVICE. The grade and proportion recommended for ORDINARY SERVICE will burn more cleanly at lower operating temperatures and will give better satisfaction.

NEVER ATTEMPT (EXCEPT IN EMERGENCY) TO MIX OIL WITH THE GASOLINE IN THE MOTOR TANK.

Measure the proportions carefully as directed and shake the mixture thoroughly in a separate can. A good five-gallon can, a pint measure and funnel, with fine brass screen soldered in it, are good investments. Never (except in emergency) fill the motor tank without straining the fuel into motor tank.

GEAR CASE LUBRICATION

GEAR CASE—Fill gear case every one to four weeks (depending on amount of service) with Mobiloil "C" or high grade lubricant of similar body and character.

CAUTION: Before using motor during *extreme* cold weather conditions, thin Mobiloil "C" by mixing 25% Mobiloil "A" with it. This will thin it to proper consistency for cold weather service.

GREASING THRUST SOCKET

When refilling gear case apply a small amount of Mobiloil "C" to the surfaces of reverse lock and thrust socket; this will prevent unnecessary wear at these points.

If the foregoing instructions on oiling and greasing are followed you should get the maximum of satisfaction and uninterrupted service from your Johnson motor.

TO START MOTORS AND ADJUST CARBURETORS

(For all motors excepting ones with geared rotary valves)

(See Pages 13 to 15 for starting models with geared rotary valves).

After first filling the gasoline tank with oil and gasoline, thoroughly mix in the correct proportion, as previously described. Open the valve on the gasoline line just below the tank. Turn knob on gas tank filler cap to open position. Float pin in carburetor will soon rise.

1. Push down on the float pin (A, Fig. 9) and hold it until the gasoline begins to overflow.
2. Open the needle valve (D, Fig. 9) at least one and one-half complete turns before attempting to start the motor when it is cold. If the weather is *extremely cold*, it should be opened two complete turns or more. Correct opening of needle valve will vary slightly on certain motors, so familiarize yourself with the needle adjustment.
3. Place the magneto lever in center directly over carburetor (except on Light Single, move lever to left over corner of hand rail).
4. Push the throttle lever (C, Fig. 9) down as far as it will go. This is in "choke" position.
5. Push Release Charger lever to right (facing motor) as far as it will go. (Single cylinder motor has no release charger.)
6. On motors not equipped with Ree-Koil starters place the knot on the end of the starting cord in one of the slots in the starting pulley and wrap around the pulley. While holding up on the steering rail or handle with the left hand, give the cord a sharp pull all the way out. The motor should start readily in one or two pulls.

CAUTION: On motors equipped with Ree-Koil Starters do not attempt to start the motor without first retarding magneto lever to center position. After pulling out on the starter handle do not release the handle but let it return slowly to the motor. Do not let it snap back.

After motor starts, move the magneto lever a little to the right, raise the carburetor lever slightly to speed up motor. Now push the release charger lev-

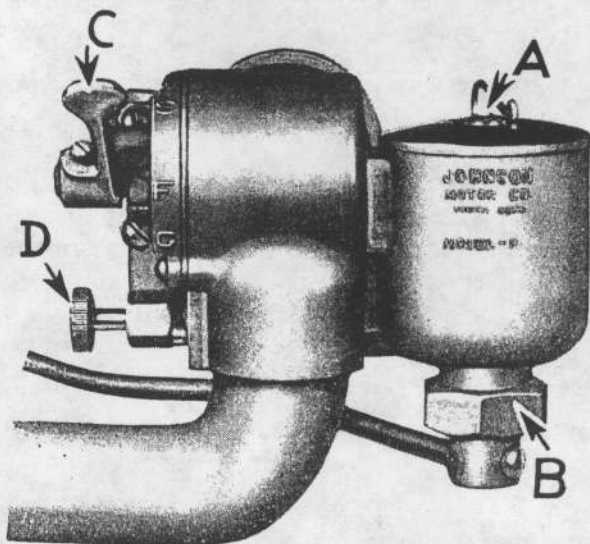

Fig. 9. Front view of carburetor showing float pin, settling basin, gas throttle and needle valve.

er quickly to left *as far as it will go*. Push magneto lever to right and raise the carburetor lever up to central position which is full speed. If the motor is cold it may be necessary to leave the carburetor lever at choke position for a few seconds until the motor warms up. Then slowly raise it to center. When motor is warmed up thoroughly, familiarize yourself with the proper setting of the needle valve by slowly adjusting it one way and the other until you determine the setting where motor runs fastest.

NOTE: If it is necessary to operate motor with carburetor lever below center (partly choked) turn on a little more gasoline at needle valve. If this does not overcome the trouble, carburetor should be cleaned out. (See Page 17).

STARTING INSTRUCTIONS FOR S-45 AND V-45 MOTORS USING FLOAT FEED CARBURETORS

Follow same instructions as for starting the previous models with the exception of carburetor choke (C, Fig. 10) which is a separate lever and should be raised up to choke position instead of pushed down, (as in the other models).

Compression Release Charger lever (A, Fig. 13) when pushed to right *as far as it will go*, releases the compression and automatically blocks the by-pass port (B, Fig. 13) leading into that side having the compression released, so the entire charge drawn in through the carburetor is delivered to the opposite cylinder.

By reducing the pressure on the spark plug in the released cylinder the spark delivered in the active or charged cylinder is automatically built up to break down the increased resistance resulting in a very hot spark.

IMPORTANT: Release charger lever should be moved to the right or left as far as it will go and *not part way*.

If motor has a tendency to back-fire, when compression release charger is pushed to left to start motor running on both sides, the release charger lever is not pushed *all the way*, or the motor was not speeded up enough before pushing the release charger lever to the left.

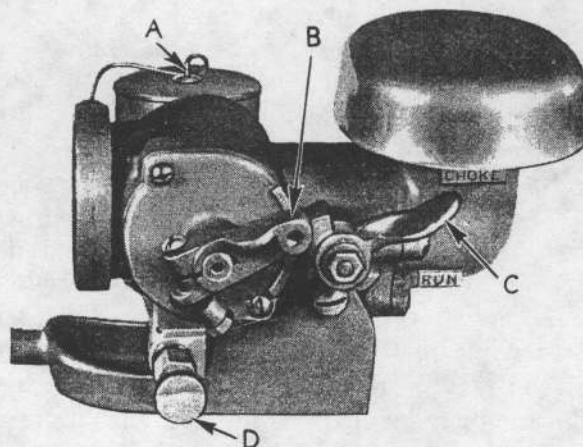

Fig. 10. Carburetor for Models S and V

Backfiring may also be caused from not having enough gasoline turned on at needle valve. Familiarize yourself with the proper setting of the needle valve while the motor is running on both cylinders.

STARTING INSTRUCTIONS FOR S-45, P-50, V-45, SE-50, PE-50 AND VE-50 MOTORS USING VACTURI FUEL LIFT CARBURETORS.

Make certain that the gasoline line and connections between the main fuel supply tank and the carburetor *are airtight*, and that the

strainer in the connection at the carburetor is free from dirt and sediment.

In starting the Vacturi carburetor, with the fuel supply tank located above the carburetor, open the needle valve as shown in the illustration (A, Fig. 11), two full turns. Press down on the carburetor tickler, shown at (B, Fig. 11) on the illustration, until fuel runs out through the small hole at the lower end of the manifold. Choke the carburetor. This is done by lifting up on the choke lever indicated at (C, Fig. 11). Set the throttle lever, as shown at (D, Fig. 11) on the accompanying illustration, to about half open position. Crank the motor. If motor does not start after the second cranking operation move the choke down to prevent flooding of the motor.

With the motor running—close the throttle *all the way* and adjust the low speed adjustment (E, Fig. 11) for the best motor performance. With the throttle fully closed the spark should be in retarded position. In making the low speed adjustment screw up (clockwise) on adjustment (E, Fig. 11) to make the mixture richer and down (counterclockwise) to make the mixture leaner.

After the low speed adjustment has been made advance the spark to its fully advanced position, open the throttle to its wide open position and allow the motor and boat to reach top speed and then adjust the needle valve for the highest motor speed. By screwing in (clockwise) on this adjustment the mixture is made leaner and by screwing out (counterclockwise), the mixture is made richer at top speed. *This needle valve should not be used as a low speed adjustment nor should the low speed adjustment be used as a top speed adjustment.*

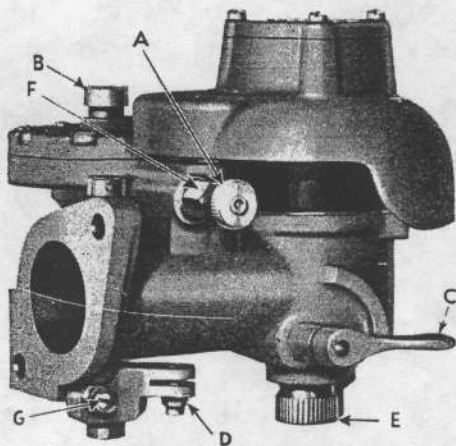

Fig. 11. Vacturi Fuel Lift Carburetor.

Make certain that the packing nut (F, Fig. 11) around the stem of the needle valve is tight. A loose packing nut will result in an air leak which will tend to make the mixture leaner at wide open throttle or top speed. A loose packing nut will also permit the needle valve to shake out of its proper adjustment.

The idling speed of the motor may be regulated by adjusting the screw (G, Fig. 11) mounted on the throttle lever. By screwing in on this adjustment the idle speed may be increased and by screwing out the idle speed may be decreased. The carburetors are set at the factory for the proper idle speed and it is not advisable for this adjustment to be changed unless found necessary.

The above instructions apply to the installations where the fuel tank is located below the carburetor with the exception that the tickler is not to be operated. With the tank located below the carburetor it is necessary to hold the choke in its fully choked position, and crank the motor until fuel is delivered to the engine, at which time, the choke should be moved down to its open position.

STARTING INSTRUCTIONS FOR ALL MOTORS USING
FLOAT FEED VACTURI CARBURETOR

Place throttle (A, Fig. 12) in about one-third open position and close the choke (B, Fig. 12). Open high speed needle valve one full turn. Press float pin (D, Fig. 12) down for a moment to insure fuel supply in carburetor. Start motor in usual way.

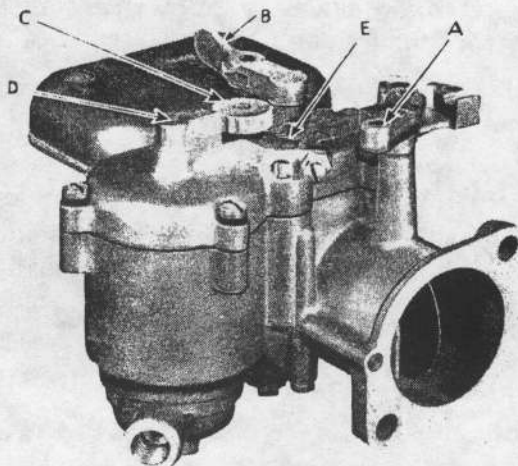

Fig. 12. Vacturi Float Feed Carburetor.

When motor has started firing regularly, open choke to running position. With wide open throttle, spark lever advanced, and the motor thoroughly warm readjust the HIGH SPEED needle valve until maximum speed is attained.

Close the throttle retard spark lever and the motor should run slowly. If a change in the idling mixture is desired adjust the LOW SPEED needle valve (E, Fig. 12) with a screw driver.

For starting warm motor do not flush or flood the carburetor, simply use the choke.

The minimum opening, or closed throttle position also the low speed adjustment (one and one half turns open) have been set at the factory and should be found correct.

NOTE: This carburetor was designed for the new model racing motors, but can be adapted and will perform equally as well on any of the regular or service motors that are equipped with fuel lift Vacturi carburetors.

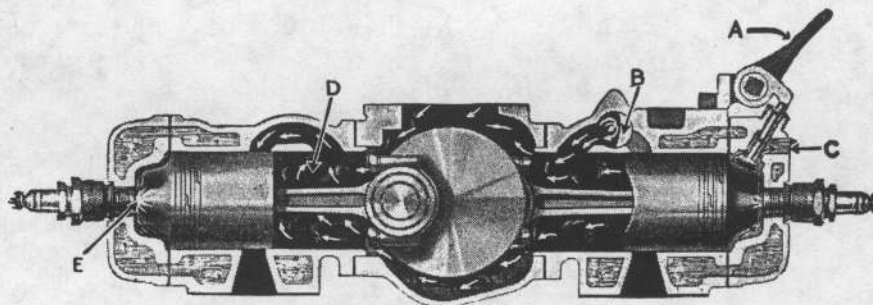

Fig. 13. The Release Charger

GENERAL DESCRIPTION OF ALL ROTARY VALVE
MODELS, EXCEPTING "A" AND "K-50-65"

These models are designed especially for high speed service and contain many new features not found in other outboard motors. The most outstanding developments are found in the following:

Rotary Valve.

Circular disc crank arms, part of one piece crank shaft, (Fig. 13).

Perfectly straight connecting rods with roller bearings using part of the rod for the outer roller race. (Fig. 13).

Detachable Lynite Cylinder heads (Fig. 13).

Improved design heat resisting Lynite pistons

BOOK OF INSTRUCTIONS

open position and the timing lever is advanced to the right when facing the motor. (The amount of advance for full speed will vary some.)

To slow down the speed of the motor, move the carburetor lever to retard position and move the magneto lever to the left (facing motor). If the motor does not run steadily at low speed, the needle valve should be opened or closed slightly.

TO STOP THE MOTOR

Press down on the button on the magneto lever until flywheel stops revolving. This short-circuits the ignition. It is well never to stop the motor by turning off the gasoline needle valve on the carburetor. On models S, P-50, PE-50 V and XR the stop button is located in the end of the steering handle.

CLEANING CARBURETOR: Should the motor stop firing suddenly or fire irregularly while running, note the position of the float pin in the carburetor (A, Fig. 9). If the pin is down, it indicates that either the gasoline tank is empty or sufficient gasoline is not reaching the carburetor. This is probably due to the presence of dirt or water in the screen or gasoline line.

Keep the carburetor clean, and above all keep dirt and water out of the gasoline tank. It is advisable to remove the strainer and also the settling basin on bottom of carburetor (B, Fig. 9) to clean thoroughly, at the same time rinsing out the gasoline tank line and carburetor with clean gasoline. Be certain that gasket is in place when replacing nut on bottom of carburetor.

Special Operating Features

FULL PIVOT STEERING

The Johnson motor is made to turn completely around, permitting the propeller to drive the boat in any direction. Should the boat be alongside a landing, it is not necessary to push it away with an oar, as you may turn the motor to a 90 degree angle, propelling the stern of the boat sideways. (This does not apply to models S, P-50 and V or any motor having underwater exhaust, except A and K-50-65).

LANDING: It is not necessary to stop a Johnson motor when making a landing unless the water is so shallow that the propeller touches bottom. You can slow the boat down to a stop by turning the motor back and forth from a reverse to a forward position. This permits you to maneuver the boat to a perfect landing and hold it in position by the motor.

NOTE: Motors having underwater exhaust cannot be turned around in reverse position, except models A and K-50-65.

REVERSING: If motor is running full speed ahead, it can be swung around backward into reverse position, bringing boat to a sudden stop. But it is usually advisable to first slow the motor down to about half speed. This applies only to motors having no underwater exhaust, except models A and K-50-65.

The Johnson motor may be steered either by holding to the hand rail or the handle.

In reversing the motor, the force of the propeller does not push the drive shaft to the surface, as it is automatically locked in the stern bracket. As soon as the motor is swung around again to forward position the lock is automatically released.

LUBRICATION OF REVERSE LOCK. The reverse lock and thrust socket surfaces should be lubricated, at the same time as the gears in the gear case, by simply rubbing a small quantity of the gear lubricant on the surfaces.

ROPE STEERING. The Johnson motor may be steered from any part of the boat by rigging tiller ropes through screw eyes and tying the ropes (crossed) to the corners of hand rail or snapping into eyelets on muffler. A complete rope or cable steering device and a steering crossbar may be purchased from any Johnson dealer.

AUTOMATIC TILTING

All Johnson motors are free to tilt up when in the forward position and upon striking any submerged object will ride over without damage. For shallow water, the thrust socket may be set out to give a permanent tilt, thus drawing less water.

In very shallow water, slow down the motor and tilt the propeller up near the surface of the water by bearing down on the handle. Always slow down the motor before doing this, however.

As before stated, the collar locks the tilting device when in reverse so that the thrust of the propeller cannot throw itself up and out of the water. Be careful, therefore, while running in reverse, not to hit anything, as the **MOTOR WILL NOT TILT IN THIS POSITION.**

CAUTION FOR UNDERWATER EXHAUST: Do not tip up the lower end of motor higher than the power head, as water may drain into motor, causing it to rust.

SHOCK-ABSORBER

(Used in Sea Horse "Single," "3", "4", "10", "12", OA-55-60-65 and OK-55 motors).

The Shock-Absorber is a clutch arrangement located inside the gear case (Fig. 14 and 18) to prevent the shearing of the brass propeller pin, which is inside the hub of propeller. In the Light Single and OA-65 the Shock-Absorber is located inside the drive shaft casing.

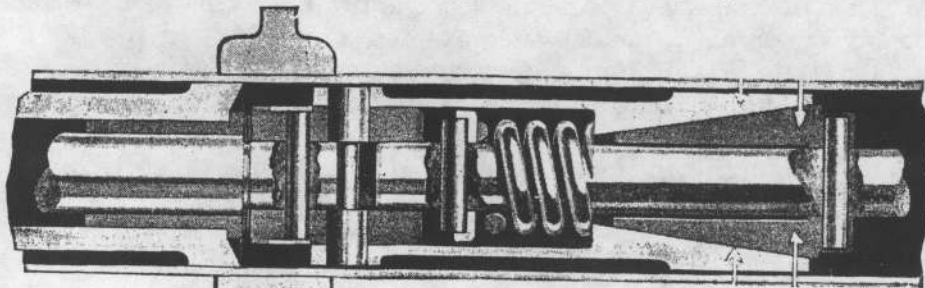

Fig. 14. Cross section of shock absorber

The Shock-Absorber operates only when the propeller strikes solid objects such as rocks, logs, snags, etc.; therefore it should require no attention.

Should the Shock-Absorber clutch slip, causing the motor to race, it should be investigated at once. A stronger spring or a washer inserted

Compression Release Charger (A, Fig. 13).

Underwater exhaust with automatic exhaust release for starting (Fig. 1).

Improved streamline design gear case (Fig. 1).

Water cooled muffler and exhaust pipe (Fig. 1).

Starting Motors with Under Water Exhaust

All motors having under water exhaust must have the exhaust valve open at time of starting. Exhaust valve on models S and V opens automatically when retarding spark for starting and closes automatically when spark is advanced.

Models A, K-50, SE-50, P and PE-50 and VE-50 have under water exhaust operating automatically (See Fig. 22).

BACKFIRING

If motor backfires upon closing exhaust valve, turn on more gasoline at needle valve and advance magneto lever. Upon opening exhaust valve after motor is running, it will be necessary to readjust the needle valve for correct running mixture.

CAUTION

On models S and V the carburetor air intake is covered (See Fig. 12) to prevent anything dropping into the carburetor intake, which would be drawn immediately into the rotary valve, causing serious damage. Don't operate motor with the carburetor intake cover removed.

SPECIAL STARTING NOTE FOR LARGE MOTORS NOT HAVING RELEASE CHARGERS

Instead of first giving starting cord sharp pull, it is well to rock the flywheel back and forth against compression several times with carburetor choked, to draw a charge into the cylinders. Then give a hard, sharp pull and motor will start very easily.

EXCESSIVE SMOKE FROM THE MUFFLER and irregular firing after motor is running for some time at full speed indicates too much gasoline. Too little gasoline results in irregular firing, lack of power, and a tendency to backfire through the carburetor. After a little experience in operating the motor, the correct setting of the carburetor needle valve becomes a simple matter.

If a cold motor fails to start—after choking, though the ignition system is found to be in working order, it is a good indication that the flow of gasoline is stopped in the carburetor, which may need cleaning out.

FLOODED MOTOR. If motor is warm be careful about flooding. Use the choke just enough to start motor. Do not push float pin down to flush carburetor while motor is warm.

If the motor should become flooded proceed as follows: Shut off the gasoline needle valve on the carburetor. Spin the motor a few times with the starting cord. As soon as it starts, open the gasoline needle valve to the usual running position, with the throttle lever open and the magneto lever well advanced to right for full speed.

TO CONTROL SPEED

The motor will operate at full speed when the throttle lever is in

BOOK OF INSTRUCTIONS

open position and the timing lever is advanced to the right when facing the motor. (The amount of advance for full speed will vary some.)

To slow down the speed of the motor, move the carburetor lever to retard position and move the magneto lever to the left (facing motor). If the motor does not run steadily at low speed, the needle valve should be opened or closed slightly.

TO STOP THE MOTOR

Press down on the button on the magneto lever until flywheel stops revolving. This short-circuits the ignition. It is well never to stop the motor by turning off the gasoline needle valve on the carburetor. On models S, P-50, PE-50 V and XR the stop button is located in the end of the steering handle.

CLEANING CARBURETOR: Should the motor stop firing suddenly or fire irregularly while running, note the position of the float pin in the carburetor (A, Fig. 9). If the pin is down, it indicates that either the gasoline tank is empty or sufficient gasoline is not reaching the carburetor. This is probably due to the presence of dirt or water in the screen or gasoline line.

Keep the carburetor clean, and above all keep dirt and water out of the gasoline tank. It is advisable to remove the strainer and also the settling basin on bottom of carburetor (B, Fig. 9) to clean thoroughly, at the same time rinsing out the gasoline tank line and carburetor with clean gasoline. Be certain that gasket is in place when replacing nut on bottom of carburetor.

Special Operating Features

FULL PIVOT STEERING

The Johnson motor is made to turn completely around, permitting the propeller to drive the boat in any direction. Should the boat be alongside a landing, it is not necessary to push it away with an oar, as you may turn the motor to a 90 degree angle, propelling the stern of the boat sideways. (This does not apply to models S, P-50 and V or any motor having underwater exhaust, except A and K-50-65).

LANDING: It is not necessary to stop a Johnson motor when making a landing unless the water is so shallow that the propeller touches bottom. You can slow the boat down to a stop by turning the motor back and forth from a reverse to a forward position. This permits you to maneuver the boat to a perfect landing and hold it in position by the motor.

NOTE: Motors having underwater exhaust cannot be turned around in reverse position, except models A and K-50-65.

REVERSING: If motor is running full speed ahead, it can be swung around backward into reverse position, bringing boat to a sudden stop. But it is usually advisable to first slow the motor down to about half speed. This applies only to motors having no underwater exhaust, except models A and K-50-65.

The Johnson motor may be steered either by holding to the hand rail or the handle.

In reversing the motor, the force of the propeller does not push the drive shaft to the surface, as it is automatically locked in the stern bracket. As soon as the motor is swung around again to forward position the lock is automatically released.

LUBRICATION OF REVERSE LOCK. The reverse lock and thrust socket surfaces should be lubricated, at the same time as the gears in the gear case, by simply rubbing a small quantity of the gear lubricant on the surfaces.

ROPE STEERING. The Johnson motor may be steered from any part of the boat by rigging tiller ropes through screw eyes and tying the ropes (crossed) to the corners of hand rail or snapping into eyelets on muffler. A complete rope or cable steering device and a steering crossbar may be purchased from any Johnson dealer.

AUTOMATIC TILTING

All Johnson motors are free to tilt up when in the forward position and upon striking any submerged object will ride over without damage. For shallow water, the thrust socket may be set out to give a permanent tilt, thus drawing less water.

In very shallow water, slow down the motor and tilt the propeller up near the surface of the water by bearing down on the handle. Always slow down the motor before doing this, however.

As before stated, the collar locks the tilting device when in reverse so that the thrust of the propeller cannot throw itself up and out of the water. Be careful, therefore, while running in reverse, not to hit anything, as the **MOTOR WILL NOT TILT IN THIS POSITION.**

CAUTION FOR UNDERWATER EXHAUST: Do not tip up the lower end of motor higher than the power head, as water may drain into motor, causing it to rust.

SHOCK-ABSORBER

(Used in Sea Horse "Single," "3", "4", "10", "12", OA-55-60-65 and OK-55 motors).

The Shock-Absorber is a clutch arrangement located inside the gear case (Fig. 14 and 18) to prevent the shearing of the brass propeller pin, which is inside the hub of propeller. In the Light Single and OA-65 the Shock-Absorber is located inside the drive shaft casing.

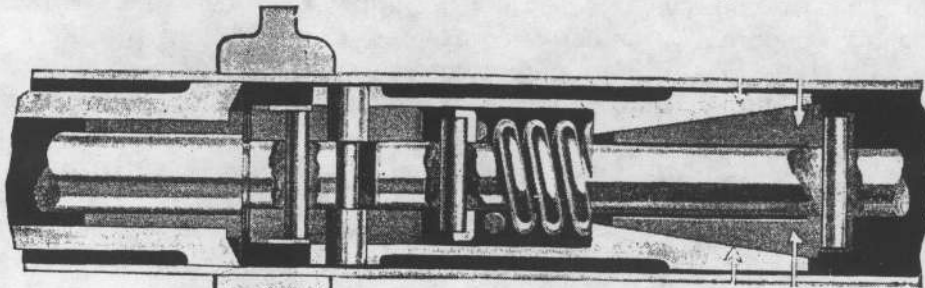

Fig. 14. Cross section of shock absorber

The Shock-Absorber operates only when the propeller strikes solid objects such as rocks, logs, snags, etc.; therefore it should require no attention.

Should the Shock-Absorber clutch slip, causing the motor to race, it should be investigated at once. A stronger spring or a washer inserted

behind the spring may be required to strengthen it, or it may be necessary to grind the cone into the gear with valve grinding compound to bring the two surfaces together perfectly (Fig. 14).

SHOULD THE SHEAR PIN BREAK on motor having Shock-Absorber it indicates that the clutch is stuck and should be broken loose by putting a steel pin in place of a brass shear pin and having someone hold the flywheel while the propeller is forced around, breaking the clutch loose. If clutch can then be slipped, remove steel pin and replace with regular brass shear pin.

The SEA HORSE "16," "24," "32" and "50" do not have Shock-Absorber, but have a brass shear pin inside propeller hub. Should you strike anything solid with propeller, the brass pin will break, thus protecting the more vital moving parts.

PROPELLER SLIPPING causing motor to race at high speed is usually caused by clutch slipping on motors equipped with Shock-Absorbers.

As there is no clutch used on larger motors you will find this slipping caused by such foreign substance as leaves, grass, paper, etc., lodging across the forward end of gear case permitting air to enter the propeller causing it to race. If the motor is stopped, the foreign substance removed, and the motor started up again, this will overcome the trouble.

CARE OF THE IGNITION

SPARK PLUG—Should the motor fire irregularly and it is found that the gasoline system is functioning properly, this is an indication of trouble in the ignition system and the spark plugs should be examined and if necessary replaced with new ones.

To test the spark, adjust the gap between points of spark plugs to .025 in. and clean free from carbon. If motor then runs perfectly the trouble lies in the spark plug. Should the motor still fire irregularly remove the plugs and replace them with new ones if necessary.

HIGH SPEED SPARK PLUGS

Due to the extreme high temperature at which high speed motors operate, ordinary spark plugs will not operate satisfactorily.

We recommend the use of a high grade high temperature spark plug of metric thread as used in motor originally.

Consult the following table for correct spark plugs for all Johnson motors.

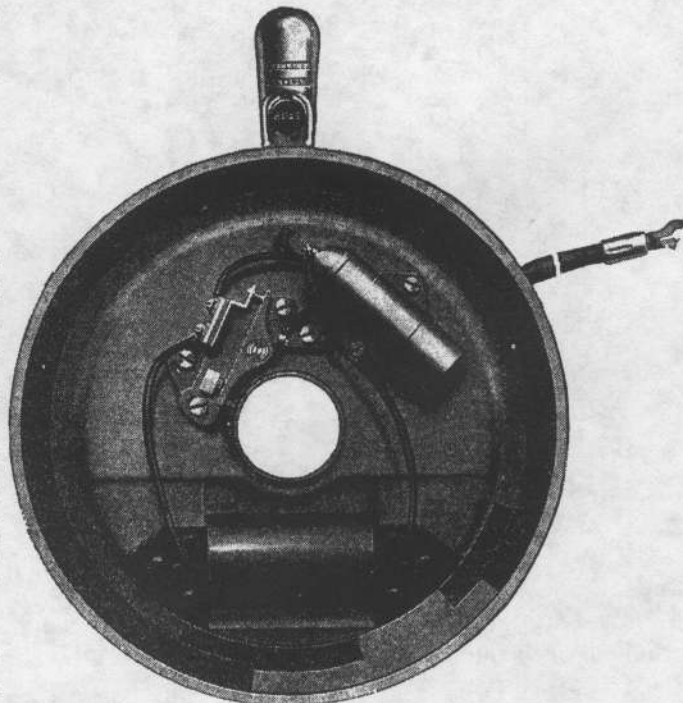

Fig. 15. Cross section of magneto in flywheel

SPARK PLUG RECOMMENDATIONS

Motor Model	Our Part No.	Spark Plug Recommended	Other Plugs that can be Substituted
All Single Cyl. models.....	76-40	AC-N-1	Champion No. C-7
A to A-45 Inclusive Old Light Twin.....	76-40	AC-N-1	Champion No. C-7
A-50 Sea Horse "4" and A-65 Models.....	76-112	Champion No. 18	AC No. 4 1/2
K-35 to K-45 Inclusive Old Standard Twin.....	76-131	Champion R-7	AC No. 4 1/2
K-50 Sea Horse "12" and K-65 Models.....	76-131	Champion R-7	AC No. 4 1/2
P-30 to P-45 Inclusive Old Big Twins.....	76-131	Champion R-7	AC No. 4 1/2
P-50 Sea Horse "24" and P-65 Models.....	76-131	Champion R-7	AC No. 4 1/2
All "S" Models Sea Horse "16".....	76-131	Champion R-7	AC No. 4 1/2
TR-40 Giant or Sea Horse "25".....	76-131	Champion R-7	AC No. 4 1/2
All "V" Models Sea Horse "32".....	76-131	Champion R-7	AC No. 4 1/2
All OA Motors Std. Light Twins.....	76-40	AC-N-1	Champion No. C-7
All OK Motors Standard Twins.....	76-131	Champion R-7	AC No. 4 1/2
Racing Motors.....	76-179	R-1-V	We recommend Champion R-1-V for all ordinary racing motors.
PR-60.....	76-130	R-11	Where special racing fuels are used and motors turning exceptionally fast.

NOTE: Champion No. R-11 and Defiance No. 23 are very cold plugs and should only be used in exceptionally fast racing motors.

IGNITION CABLES—Cables should be kept free from gasoline and oil. Care should be taken to see that nothing rubs or chafes them to cut through the insulation. Should the rubber insulation become cracked or broken, replace the cables with new ones at once.

MAGNETO—The magneto has no bearings and as it requires no

NOTE: The correct spark plugs to use in any motor depends upon kind of service to which the motor is subjected.

Spark plugs furnished in motor, as regular equipment, are for ordinary service.

Should you use the motor on extremely light weight fast boats and operate it at top speed for hours, some motors may burn plugs, now and then, and it may be necessary to use slightly colder plugs.

At extreme slow trolling speeds some plugs have a tendency to foul, from oil not burning off the porcelain—in such cases, a warmer plug may be required, likewise this plug would get too hot running at full speed. This is a case of extreme heat range and may be hard to control by the use of one plug.

BOOK OF INSTRUCTIONS

lubrication, seldom needs attention. Once each season remove the starting pulley thus exposing the inspection hole. Move the flywheel so that the inspection hole is directly over the contact points. With the .019 inch feeler gauge on the handle of the magneto wrench, test the opening of the contact points.

CAUTION: Do not try to adjust breaker points turning contact screw point. Loosen screw (A, Fig. 15) and move breaker base in or out.

If the contact points are rough or pitted, they may be dressed slightly on the contact surface by drawing a narrow strip of "00" sandpaper between them several times. Fold the strip of sandpaper so that there is sand on both sides, thus polishing both points at the same time.

It is usually best not to attempt any repairs on magneto if real trouble is encountered. Remove the complete magneto and return it to the nearest Service Station. *Be sure to send the complete flywheel and armature plate.*

REMOVING MAGNETO

(On Light Single only)

To remove the magneto, take off the starting plate on the top by removing the three screws. Then remove the nut and lockwasher from the end of the crankshaft and replace the nut so that it is just flush with the end of the crankshaft. By lifting up on the rim of the flywheel the whole motor is suspended. By striking the nut and end of the crankshaft a sharp blow with a hammer, while held in this manner, the tapered crankshaft is driven out of the tapered hole in the flywheel hub. Remove the nut and lift the flywheel off. The armature plate may then be lifted off after unloosening the clamp screw on the underside of armature plate. When replacing armature plate, apply a small amount of grease to bearing surface in armature plate hub.

In replacing the flywheel, see that the crankshaft and the hole in the flywheel hub are clean and that the flywheel does not ride on the keys. Place a drop of oil on crankshaft taper and distribute over taper before placing flywheel on shaft. Be sure that the keys do not drop out when putting the flywheel back on. After examining the flywheel in this manner, tighten the nut on the end of the crankshaft. *This nut must be tight.* Someone must hold the flywheel for you, with both hands to keep it from turning, while you pull the nut up tightly with a big wrench.

IF MAGNETO LEVER WORKS LOOSE—Should the magneto lever become too loose or too tight in the ordinary operation of the motor, this can be very easily adjusted. On the under side of the magneto (outside) you will find a screw in the hub of the armature plate, close to the crankcase. This screw can be tightened or loosened as is necessary.

REMOVING MAGNETO

(On all Models except Singles)

The large nut on top of flywheel screws on the end of crankshaft. By simply unscrewing the nut, the flywheel is automatically lifted off. The nut is flanged, acting as a flywheel puller against the inside of the nameplate on flywheel.

NOTE: Nameplate must not be removed until after the nut is unscrewed or it will not lift flywheel off.

JOHNSON MOTOR COMPANY

If flywheel sticks and seems hard to remove, unscrew nut until considerable pressure is exerted on it. Remove wrench, have some one lift up on the flywheel rim so as to suspend motor by flywheel and while held in this position strike sharply on the top of nut with a hammer. This will loosen the flywheel from the shaft and it can then be easily removed by unscrewing the nut.

When replacing magneto pay particular attention to securing the large flywheel nut tightly. *This nut must be tight* or trouble is certain to develop from running with loose flywheel which can easily be detected by a sharp knocking sound while motor is running.

GEARS

The gear case should be filled with a high grade semi-fluid lubricant of the body and character of Mobiloil "C". To fill the gear case, remove the filler plugs on the side of the case and insert the lubricant in lower hole by means of special cartridge or grease gun. If no grease gun or cartridge is at hand, remove the gear case head and pack the case with lubricant, being careful not to injure the gasket when replacing gear case head. (See Figures 1 and 2 for location of these parts.)

The operator must determine by frequent observation just how often the gear case must be lubricated as conditions vary. In hot weather, especially in the South, it will require attention more frequently than when used in the cool lake waters of the North. Under ordinary conditions, where the motor is used a few hours each week, the gear case should not require filling more than once a month, but check up on the grease just the same.

IMPORTANT

When storing the motor for any length of time, drain the gear case of water by removing the gear case head and repack with fresh lubricant as otherwise the gears may rust, causing serious damage later.

If lubricated correctly the gears will run for a long period without adjustment. If, for any reason, they should have to be adjusted, great care must be exercised in making the adjustment, otherwise the gears and bearings may be ruined.

GEAR ADJUSTMENT—The gear case is provided with an adjusting screw on the end opposite the propeller, and a lock screw in the gear case for holding the end thrust bearing in place and to prevent it from turning. (See Figures 1 and 2.)

To adjust the gears, proceed as follows: First, loosen the lock screw in the gear case. This loosens the end thrust bearing. By means of the adjusting screw, in the end of the gear case, the gears may be loosened or tightened.

The proper adjustment of the gears may be best determined by carefully turning the flywheel with one hand with both spark plugs removed, and at the same time, turning the adjusting screw with the other hand. The gears should mesh as close as possible and still permit the flywheel to turn freely. Do not fail to lock screws with the lock nuts after adjusting the gears. Don't operate motor with gears too tightly in mesh.

PRESSURE-VACUUM COOLING SYSTEM

(Used on all models except Light Single, OA and OK-55-60 Motors)

An abundant supply of water is forced through the water jackets of

the cylinders at all times while the motor is in operation by the force of the propeller. The action of the propeller also causes a suction which pulls the water through the discharge port, thus securing the full action of the pressure and vacuum created by the propeller. This system eliminates all pump moving parts that are subject to wear.

CAUTION: Never operate the motor with the propeller removed nor when the shear pin in the propeller is broken. No water will be forced through the cooling system and motor will become overheated.

To drain water from cooling system simply stand motor in upright position on the skog of gear case and rock motor back and forth until all water has drained from water intake and outlet.

PUMP ON LIGHT SINGLE

The Light Single Cylinder motor has a positive plunger pump cooling system. Water must be drained from cooling system by removing screw in side of pump and standing motor upright until all water drains out before exposing motor to freezing temperature.

When packing gear case on Single Cylinder motor with lubricant do not force it in too tightly as it may interfere with action of pump plunger.

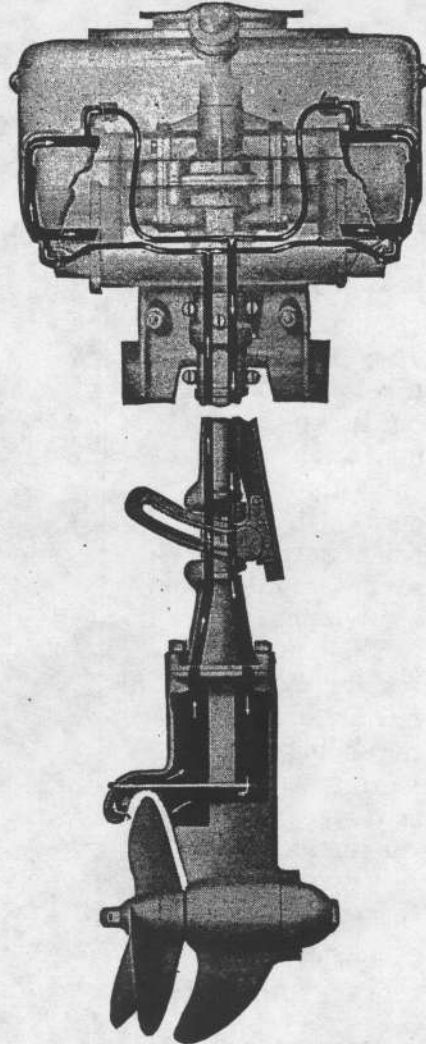

Fig. 16. Phantom view of new Pressure-Vacuum Cooling System

GENERAL DESCRIPTION OF OA-55 AND OK-55 MODELS

The Standard Twin motors, models OA and OK-55-60, are of the two cycle, valveless, high-speed opposed cylinder type.

Both motors are water cooled by an improved type, sliding vane eccentric pump having no valves. In both motors the discharged water from the cooling system is discharged into the the under water exhaust pipe, which makes the motor very quiet in operation and free from the fumes of burnt gases. A built-in flywheel magneto furnishes ignition.

These two motors are very similar to the Sea Horse "3," model A-45, and the Johnson Sea Horse "10", model K-45.

OPERATION OF WATER PUMP ON OA-55 AND OK-55 MOTORS

The water pump on the Johnson Light Twin and Standard Twin is a new improved sliding vane pump having no valves (See Fig. 17). The eccentric C is keyed to the propeller shaft and revolves

with it. Water is drawn through the opening (A and E, Fig. 17) and by the action of the eccentric (C, Fig. 17) the water is forced through the opening (B, Fig. 17) where it travels through the gearcase to the water tubes by means of a groove in the gearcase head and matched hole machined in the gearcase. Pressure is exerted on sliding vane (D, Fig. 17) by spring (F, Fig. 17) holding vane against eccentric, sealing the eccentric and preventing water escaping only through the outlet (B, Fig. 17) which carries water supply into the cooling system.

This pump will require no adjustment. The end of the sliding vane may wear somewhat after long periods of use in limestone or silty waters. Should this occur it may cause a decrease in the efficiency of the pump. To overcome this condition remove vane and polish the end, resting on eccentric, with a fine hone so that it will fit the eccentric perfectly.

CAUTION: Do not lay motor down with the propeller end higher than the powerhead as water may drain back into cylinders, rusting them seriously.

ADJUSTMENT OF GEARS IN LOWER UNIT OF OA AND OK-55-60 MOTORS

If excessive play should develop in bevel gears it will be necessary to add shims between thrust washer and bevel gear (See Fig. 18). To make an adjustment, remove propeller and pump housing. Then remove gearcase head and use shims as needed between thrust washer and bevel gear in order to take up play. (See arrow, Fig. 18). To determine correct gear adjustment remove spark plugs in motor and turn flywheel slowly. Motor should rotate freely with no noticeable play in gears. If gear adjustment is too tight the flywheel cannot be turned easily and gear chatter can be felt. Use shims No. .002 and .003, as listed in parts catalog under parts numbers 33-50 and 33-51, respectively.

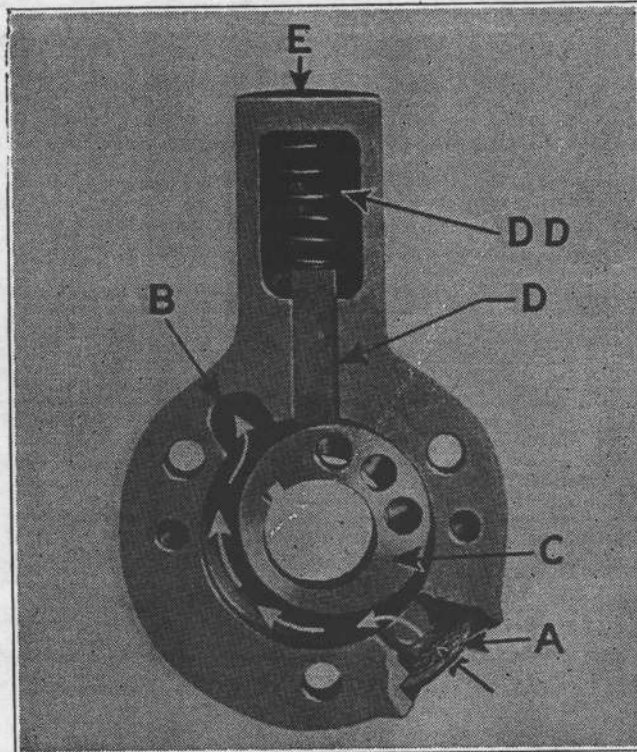

Fig. 17. Front view of water pump OA-55 and OK-55 motors showing water inlet and action of pump

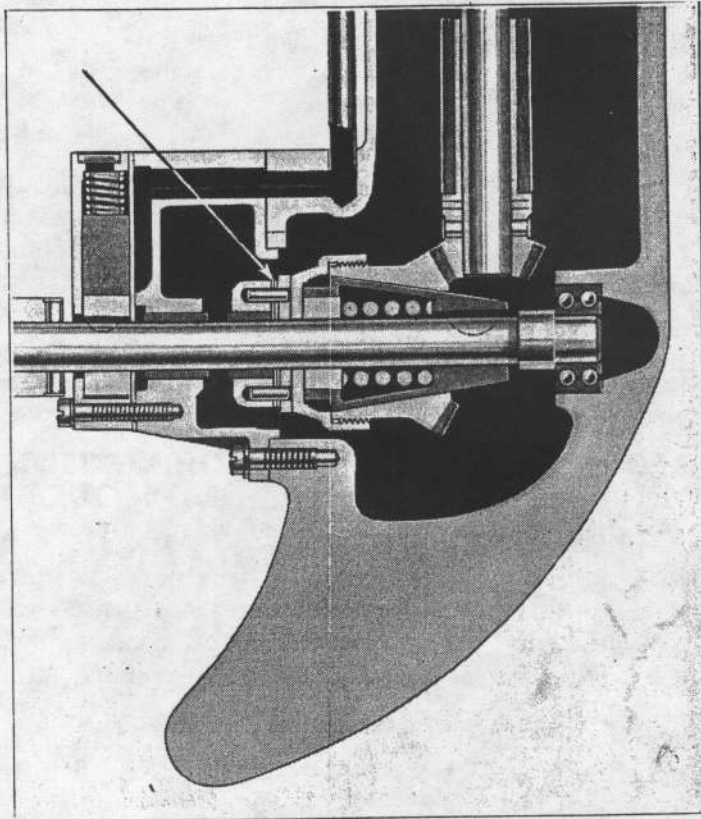

Fig. 18. Lower unit

DESCRIPTION OF ROTARY VALVE

Excepting ones on "A" and "K-50-65" Motors

The Rotary Valve, (Fig. 19), which is cylindrically formed and which controls the admission of gas from the carburetor to the crankcase, is driven by gears from the crankshaft. It opens the passage from the carburetor to the crankcase for approximately 180 degrees. Being set for the proper interval of opening and closing, full charges are fed into the crankcase, even at maximum engine speeds, thus insuring higher power peaks.

TIMING OF ROTARY VALVE: Remove the spark plug (E, Fig. 13) from the cylinder and insert a narrow steel scale through one of the spark plug holes (four cylinder motors time from top of bank of cylinders) so that it will come to rest on top of the piston.

Slowly turn flywheel in the direction in which it runs when motor

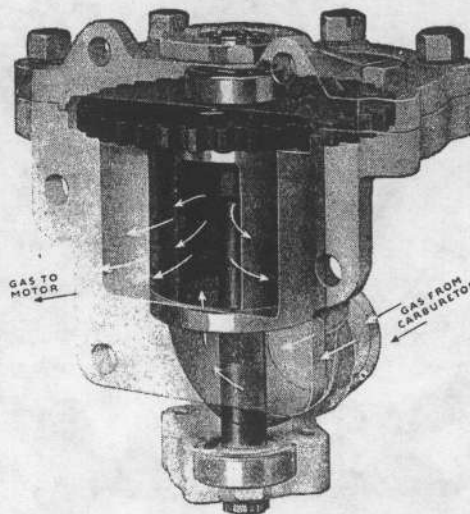

Fig. 19

is operating until the piston has reached top dead center and travelled the following distance on the downward stroke:

- $\frac{1}{2}$ " on Sea Horse "16" and "32" regular motors.
- $\frac{5}{8}$ " on Sea Horse "16", "32" and "50" racing motors.
- $\frac{9}{16}$ " on Sea Horse "24" regular motor.
- $\frac{3}{4}$ " on Sea Horse "24" racing motor.

Letter "J" (A, Fig. 19) which is stamped on the rotary valve gear should appear in the inspection hole (B, Fig. 19) of rotary valve. If it does not appear, remove the rotor assembly (Fig. 19) from motor and turn rotor (C, Fig. 19) until the "J" appears, then replace in this position.

After assembling the rotary valve to the motor it should be checked again to be sure that piston is the correct distance on the downward stroke when the letter "J" appears in the inspection hole.

INSTRUCTIONS ON CARE AND OPERATION OF MODEL A-50 SEA HORSE "4" AND MODEL K-50 SEA HORSE "12" A AND K-65

The following information is to familiarize the owner of a Sea Horse "4" or "12" with a few special features concerning his motor that are not covered in the foregoing part of this book.

Please read the entire instruction book as there is much information contained in it that applies to all Johnson motors as well as yours.

The illustrations that follow are for the purpose of familiarizing the motor owner with the workings of these two models which differ from previous models in several ways.

FEATURES OF THE NEW A-50-65 AND K-50-65 MODELS

ALTERNATE FIRING

Note the following. (Figure 20.) Instead of firing simultaneously (one explosion to each revolution) as in other Johnson models, these motors fire alternately (2 explosions to each revolution) reducing the torque on steering handle and cutting down on the vibration to a marked degree.

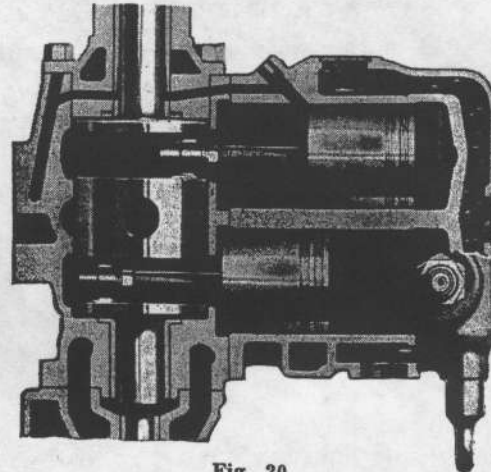

Fig. 20

ROTARY VALVE AND CRANKSHAFT IN ONE PIECE

This construction has eliminated rotary valve and crankshaft gears resulting in fewer moving parts and no gear noise. (See Fig. 21.)

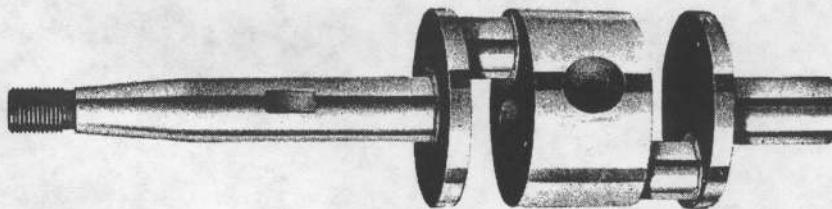

Fig. 21

UNDERWATER EXHAUST DISCHARGING INTO DRIVESHAFT CASING

This eliminates the exhaust pipe found on other motors extending down into the water back of the motor, makes possible full pivot steering and complete reverse without stopping motor (Figure 22).

AUTOMATIC EXHAUST CUTOUT

When motor speed is reduced to almost its minimum the exhaust cutout automatically opens from lack of water pressure, or if motor is stopped the cutout remains open to facilitate easy starting, with no back pressure, and as soon as motor is started and speeded up exhaust valve automatically closes by water pressure and the exhaust is discharged below the water line resulting in a very smooth running motor with no disagreeable exhaust noise.

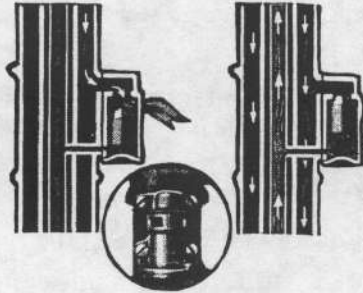

Fig. 22

If the cutout remains closed or open and will not automatically operate it will be necessary to remove the four screws (Fig. 22) which hold the cutout assembly to driveshaft casing. Also remove the two screws in bottom of cutout casting giving access to cutout plunger. Clean out any sand or other foreign matter that may be found inside.

To remove the cutout plunger from the cutout casting on model K-50, retaining ring must be removed from bottom of casting.

Greatly Improved Magneto

Waterproof coils — proof against submersion — hotter spark at slow speed — better breaker for high speed work— better insulation against dampness. (Figure 23.)

Ignition Leads

The ignition leads running from magneto to spark plugs should be connected to the proper plugs. Upper lead is marked "Top" on metal band clamped around the rubber cable.

No Exposed Water Pipes to Become Damaged

Simplified construction. Better appearance.

Attaching Motor to Boat

It is very important that the stern of the boat be of correct height and angle to permit the

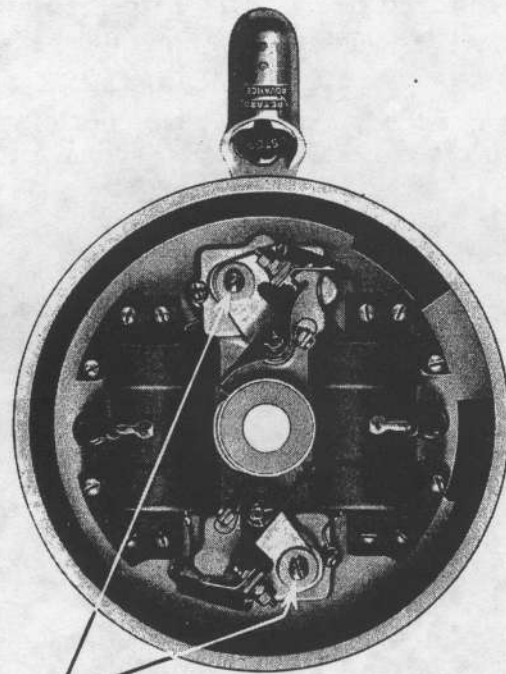

ADJUSTING SCREWS

Fig. 23

motor to set perpendicular and the anti-cavitation plate at least 1½ inches below the bottom of stern. (See Pages 8 and 9).

MIXTURE OF OIL AND GASOLINE

All Johnson motors are oiled by mixing a quantity of heavy lubricating oil such as Moiloil Marine with ordinary gasoline. Follow the recommendations and mixture ratio as directed under Motor Lubrication table (Pages 10 and 11).

STARTING THE MOTOR

The Sea Horse "4" and "12" are very easy starting motors. Follow general starting instruction on Page 12.

The only difference between starting these models and others is that the carburetor lever must be pushed *all the way down to choke* each time the motor is started again. *Always use the choke before starting.*

GREASING THE GEARS

Examine the gear case by removing vent plug and grease plug (see Figures 2, Page 5) at least once each week if motor is used daily. If used only occasionally, examine it once each month. There should *always* be grease in the gear case. (See page 11.)

EXHAUST PASSAGE IN DRIVESHAFT CASING

The driveshaft casing (Fig. 22) designed with passages inside of it for the purpose of exhaust gases passing down and under water, thus eliminating the outside exhaust pipe such as used on other under water exhaust models. This allows full pivot of motor.

After considerable use of motor, these exhaust passages in driveshaft casing may become clogged with carbon, creating back pressure on pistons, causing motor to start hard and loss of power. In this event, remove the power head and gear case from driveshaft casing, and send casing to the nearest service station (a list of service stations will be found on pages 34 and 35) for repairs or replacement.

GENERAL CARE OF THE MOTOR

After taking the motor out of the water, it is advisable to wipe it off and drain the water system by standing it in an upright position.

This is especially recommended when running in salt water. Water can be drained from the Single Cylinder motor by removing screw in side of pump and standing motor upright.

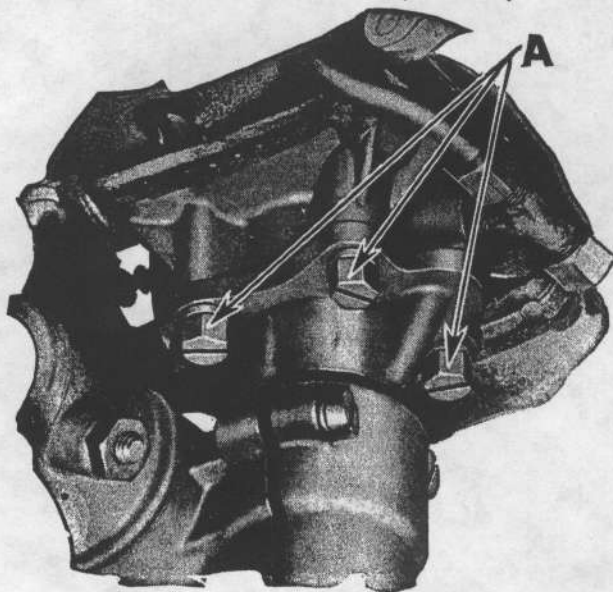

Fig. 24. Underside of power head showing take down screws

TAKE-DOWN FEATURE

When the Sea Horse Single, and Sea Horse "3" are to be put into a carrying case for checking on train as baggage it may be taken apart easily and quickly by removing the four screws or nuts (A, Figure 24).

When motor is reassembled, care must be exercised to see that the gasket between the two parts is not torn and is in good condition. Care should also be taken to see that the water passage holes are not partially covered by the gasket. Should the original gasket become torn, a new one can be made from tough, thick paper, which, when in place, should be varnished or shellacked on one side only and oiled on the other side. A gasket prepared in this manner will stick to only one surface and will not be torn when it is removed.

STORING THE MOTOR

In order that the motor may be in the best condition when it is put into service again, it should be carefully put away in the Fall.

All gasoline should be drained from the tank and from the carburetor. The water should be drained from the cooling system by standing motor in an upright position and rocking back and forth. On S, P-50 and V models remove outlet water drain plug (Fig. 1) from pinion case. Polish all the bright parts with nickle polish and wipe the motor off with an oily cloth. Remove the spark plugs and pour about a teaspoonful of engine oil into each cylinder. Then turn the flywheel a few times to thoroughly distribute the oil on the inside of the cylinders and pistons and replace spark plugs. Remove the power head from the lower unit and pour out the water and oil from the driveshaft column. Also remove the gear case head, drain all the water from the gear case and fill with fresh gear lubricant. (Mobiloil "C").

Store the motor in a dry place with the hand rail down and the tank up, except Sea Horses "4", "12", "16", "24", "32" and "50" which are designed to lay with tanks down. Cover motor with an old rug or burlap.

Never store the motor in an inverted position; there may be some water in the driveshaft housing which will run into the crankcase and cylinders, causing serious rusting.

Before placing the motor in service in the spring, thoroughly wash off all grease with gasoline and inspect the entire motor to see that it is in good condition.

Pack the gear case with fresh gear lubricant, if this was not done when motor was stored away.

Remove the starting plate on the top of the flywheel, turn the inspection hole over the contact points, and clean the points by running a narrow strip of "00" sandpaper, folded so that the sand is on both sides, between them. See that the contact points open the proper distance as has been explained previously. If not, adjust them to the proper setting. (Don't try to turn the contact points on the "4", "12", "16", "24", "32" or "50"; see pages 20 and 21).

Clean the screens in the gasoline tank and bottom of the carburetor. Be sure to clean the gasoline tank, the gasoline feed pipe and the carburetor with clean gasoline.

Thoroughly clean the spark plugs. If porcelain is chipped or broken, replace with new plugs or metric thread. Set the gaps to exactly .025 inch. (See Page 20).

Remove the muffler and exhaust castings and clean all the carbon from the exhaust port in each cylinder and from the holes in the muffler. In replacing the exhaust castings, be sure that the surfaces are clean and use new gaskets unless the old gaskets are found to be in perfect condition.

After the motor has been placed in the water and started, adjust the carburetor as previously explained. See that water is circulating properly by holding your hand on the ends of cylinders while motor is running full speed; the cylinders should be cool while motor is running.

It is also advisable to tighten all screws two or three times after the motor has been in operation the first day or two.

It should not be necessary to give the motor a thorough overhauling until after a number of years of ordinary service. After a very long period of continuous hard usage, however, a complete overhauling may be necessary. This should be done by an experienced mechanic. Many Johnson dealers have such service available. (See pages 34 - 35).

CARBON IN MOTOR

Once each season the exhaust manifolds should be removed and any carbon accumulation in the castings or in the exhaust ports in the cylinder cleaned out.

Should the motor lose compression after a long period of use, remove both cylinders, scrape all carbon from the piston tops, ends of cylinders and exhaust ports. If piston rings are stuck tightly in the ring slots, they may be loosened by soaking in kerosene over night and then working until loose. If the rings are baked in the pistons, about the only way to remove them is by breaking the rings in small pieces. Be sure and scrape the ring slots in pistons using a dull blade of pocket knife so the ring will seat properly; then install new rings.

LOSS OF POWER

If the motor loses power from no apparent reason, look for the cause in the order mentioned below:

1. Examine your fuel mixture. Be sure you are using the right kind of oil mixed in the proper proportion, as directed, and that it is clean.
2. Clean out the gasoline line, gasoline tank, screens and carburetor.
3. Clean and adjust the points on spark plugs properly.
4. See that the magneto lever is not advanced too far.
5. Be sure there is grease in the gear case.
6. Clean out the exhaust ports in each cylinder.
7. Be sure both cylinders are firing (both cylinders fire at the same time on all models except Sea Horse "4", "12" and A-K-65 and it may be difficult to tell when one stops, only that the motor will slow down to half speed or less). A bad spark plug will usually be the cause of the trouble.

KNOCKING

The Johnson outboard motor will not knock while running steadily from loose connecting rods or journal bearings. In case of an audible knock, turn on a little more gasoline at needle valve, then cut down on the needle valve. If knock continues, something is radically wrong and the motor should not be run in this condition. Take out the spark plugs and adjust the points and clean the plugs. If the motor runs steadily, but still continues to knock, stop immediately and with a large wrench securely tighten the nut holding the flywheel on the crankshaft. (It will be necessary that someone else hold the flywheel rim with both hands to keep it from turning while tightening this nut.) If the above suggestions do not eliminate the knocking, immediately turn motor over to a good Johnson motor mechanic.

Do not continue to operate motor if it knocks.

CARE OF MOTORS WHEN USED IN SALT WATER

Regardless of the material used in the construction of an outboard motor, it will corrode and tarnish to a certain extent when used in salt water. It is of importance, therefore, to adhere closely to the following instructions if you want to receive the most from your motor.

1. Remove the motor from the boat when it is not in use.
2. Flush out the cooling system with hydrant by running fresh water into the water instake until it flows freely from the outlet.
3. Rinse off thoroughly with fresh water.
4. Wipe dry with a cloth.
5. Go over all the bright parts with an oily cloth, especially if the motor is to be stored for any length of time.

IF MOTOR IS DROPPED OVERBOARD

Recover motor from water quickly and remove gasoline tank, carburetor, magneto, spark plugs and gasoline line.

Drain all water from motor, carburetor, gasoline tank and gas line and wash out with clean gasoline.

Wipe magneto perfectly dry, replace flywheel on motor and pour about a tablespoon of lubricating oil in the cylinders through the spark plug holes, revolve the flywheel to work the oil through motor.

Replace all parts, put new clean fuel in tank and motor should start easily.

NOTE: Do not crank motor immediately upon removing from the water without first drying out magneto, as the drops of water inside may short circuit the coil and ruin it.

*Propeller Efficiency
and*

Your Outboard Motor

How to Select the Right Propeller

To get maximum performance and service from your outboard motor it must be equipped with a propeller suited to the weight, design and speed of the boat on which it is to be used.

High speed, light weight boats require HIGH PITCH propellers. Slow moving, heavy boats require LOW PITCH propellers.

If the pitch of a propeller is too high it will hold the motor down to fewer revolutions per minute and will result in loss of power and speed. If the pitch is too low it will increase the revolutions per minute to an excessive number and may ruin the motor by racing it.

How to Alternate Between Two Propellers for Varying Uses

When the same motor is used on boats of different design and types or on the same boats for fast travelling at one time and for pushing heavy loads at another—then two different propellers are required. A high pitched wheel for speed work—a low pitch wheel for pushing heavy loads.

Refer to Following Charts

The propeller best suited for the boat you select can be easily located on the following charts.

If you own a Sea Horse "Single" or a Sea Horse "3", "4" OA, OK-55-60 your propeller problem is a simple one. Each of these

models has only one propeller which will perform satisfactorily on practically all types of outboard boats.

If you own a higher powered Sea Horse you can secure the correct propeller as indicated in the chart.

For best results use only Johnson propellers on Sea Horse motors. They are designed to match the motor and our long experience has provided a propeller for practically every need.

How "Pitch" Controls the Speed of the Motor and Performance of Your Boat

A propeller revolving in water operates like a screw advancing through the threads of a nut. The angle at which the threads of the screw are cut determines the distance it will advance into the nut in one complete revolution.

When a screw advances through a nut each revolution moves it forward a distance equal to the pitch of the screw.

So, in marine motors, the angle of the propeller blades determines the distance it will advance through the water in one complete revolution. That distance is called the pitch of the propeller. For example, a propeller having a pitch of 10 inches would advance exactly 10 inches in one revolution, providing it was operating in a solid substance that would not permit it to slip. But water is not an absolute solid. Hence the propeller does not move forward a distance equal to the pitch of the propeller, and this loss of theoretical advance in the propeller is called "Slip." This is also brought about by the fact that the hull of the boat offers resistance to forward motion which increases "slippage."

Keep Motor at Proper R.P.M.

The correct propeller reduces slippage to a maximum. It permits the motor to turn at the correct number of R.P.M., to push the weight and design of boat for which it is built. If the propeller is of too high a pitch its greatest angle takes such a deep "bite" as it turns that the water resistance thus set up slows down the speed of the motor to less than the R.P.M. of maximum power. In other words, the motor cannot turn the propeller fast enough.

Propellers pitched too low take a shallow "bite" into the water. They encounter less resistance, hence, turn too fast and permit the motor to race dangerously.

Remember this: Heavy, slow boats require low pitch propellers. Fast, light boats require high pitch propellers.

HORSE POWER AND RECOMMENDED R.P.M. FOR MAXIMUM MOTOR PERFORMANCE

NOTE: Suitable propellers should be selected to allow motors to turn at their recommended r. p. m., at which point they develop their maximum efficiency.

Model Motor	Horse Power	R.P.M.	Model Motor	Horse Power	R.P.M.	Model Motor	Horse Power	R.P.M.
Lt. Twin "A"	2	2250	PR-40	25.75	3500	SR-55	20	5500
A-25	2+	2400	A-50	4	3500	PR-55	30	5500
A-35	2½	2600	K-50	8	35.00	VR-55	40	5500
A-45	3	2700	S-45	13	4000	SE-50	13	4000
Single	1.5	2700	P-50	20	4000	PE-50	20	4000
K-35	6	2750	V-45	26	4000	VE-50	26	4000
K-40	7.15	3500	KR-55	14	5500	XR-55	50	5500
KR-40	9	3700	OA-55	3	2800	J-65	1.4*	3000
K-45	7.15	3500	OK-55	8	2800	OA-65	2.8*	3000
P-30	6	2500	SR-45	16	5200	A-65	4.1*	4000
P-35	8	2750	PR-50	24	5200	K-65	9.2*	4000
P-40	13.15	3700	VR-45	32	5200	S-65	13.3*	4000
PR-40	16.5	3800	SR-50	16	5500	P-65	21.4*	4000
P-45	12	3000	VR-50	32	5500	V-65	26.1*	4000

*Certified N.O.A. Brake Horse Power

BOOK OF INSTRUCTIONS

JOHNSON PROPELLERS

Model	Propeller No.	Material	Diam.	Pitch	Blades	Shaft Diam.	Heavy Boat	Medium Boat	Racing Boat
All Single Cyl's.....	11-22	Lynite	7 $\frac{7}{8}$	5 $\frac{1}{8}$	2	1 $\frac{1}{2}$	x	x	x
Old Lt. Twin.....	13-67	Lynite	8	7	2	1 $\frac{1}{2}$	x	x	x
A-25 Lt. Twin.....	13-569	Lynite	8 $\frac{7}{8}$	6 $\frac{1}{2}$	2	1 $\frac{1}{2}$	x	x	x
Old Lt. Twin (Salt).....	13-266	Bronze	8	7	2	1 $\frac{1}{2}$	x	x	x
AB-25 Lt. Twin.....	13-623	Bronze	8 $\frac{7}{8}$	6 $\frac{1}{2}$	2	1 $\frac{1}{2}$	x	x	x
A-35 Lt. Twin.....	13-378	Lynite	9 $\frac{1}{8}$	7.7	3	1 $\frac{1}{2}$	x	x	x
A-45 Sea Horse "3".....									
A-50 Sea Horse "4".....	25-73	Lynite	9 $\frac{1}{8}$	6	3	1 $\frac{1}{2}$	x	x	x
OA-55 Std. Twin.....	32-11	Lynite	9 $\frac{1}{8}$	8	2	1 $\frac{1}{2}$	x	x	x
K-35 Std. Twin.....	15-103	Lynite	10	10	3	5 $\frac{5}{8}$	x	x	
K-35 Std. Twin.....	15-105	Bronze	10	12	2	5 $\frac{5}{8}$			x
K-40 Std. Twin.....	15-153	Lynite	10 $\frac{1}{4}$	13.02	3	5 $\frac{5}{8}$	x	x	
K-45 Sea Horse "10".....									
KR-40 Std. Twin.....	15-154	Bronze	10	14.916	2	5 $\frac{5}{8}$	x	x	x
K-45 Sea Horse "10".....									
K-50 Sea Horse "12".....	27-57	Lynite	9 $\frac{1}{4}$	7 $\frac{3}{4}$	3	5 $\frac{5}{8}$			x
KR-55 Sea Horse "12".....	27-102	Bronze	8 $\frac{3}{4}$	12	2	5 $\frac{5}{8}$			x
OK-55 Std. Twin.....	34-11	Lynite	10 $\frac{1}{4}$	13	2	5 $\frac{5}{8}$	x	x	x
PR and P-40 Big Twin.....	7-109	Lynite	10 $\frac{1}{8}$	12 $\frac{1}{2}$	3	3 $\frac{3}{4}$			x
PR and P-45 Sea Horse "14".....									
PR and P-45 Sea Horse "14".....	7-192	Bronze	10 $\frac{1}{8}$	12 $\frac{1}{2}$	3	3 $\frac{3}{4}$		x	x
PR and P-40 Big Twin.....									
P-35 Big Twin.....	7-284	Bronze	10 $\frac{1}{4}$	11 $\frac{1}{2}$	2	3 $\frac{3}{4}$		x	
All Big Twin & Sea Horse "14".....	7-277	Lynite	10 $\frac{3}{32}$	8	4	3 $\frac{3}{4}$	x		
P-35 and P-40 Big Twin.....	17-92	Bronze	10 $\frac{1}{4}$	12 $\frac{1}{4}$	2	3 $\frac{3}{4}$			x
P-45 Sea Horse "14".....									
P-35 and P-40 Big Twin.....	17-94	Lynite	10 $\frac{1}{4}$	10 $\frac{1}{2}$	3	3 $\frac{3}{4}$		x	
P-45 Sea Horse "14".....									
PR-40 Big Twin.....	17-141	Bronze	10 $\frac{1}{4}$	13 $\frac{1}{4}$	2	3 $\frac{3}{4}$			x
PR-45 Sea Horse "14".....	19-105	Bronze	11 $\frac{3}{4}$	18.1	2	7 $\frac{7}{8}$			x
TR-40 Sea Horse "25".....									
TR-40 Sea Horse "25".....	19-215	Bronze	12	13	3	7 $\frac{7}{8}$	x	x	

Model	Prop. No.	Material	Diam.	Pitch	Blades	Shaft Diam.	Service
SA & SE-50 Sea Horse "16".....	21-288	Bronze	10"	11"	2	3 $\frac{3}{4}$ "	Note 1*
SE-50 Sea Horse "16".....	21-179	Bronze	10"	17"	2	3 $\frac{3}{4}$ "	Note 2*
SE-50 Sea Horse "16".....	21-292	Bronze	10"	14"	2	3 $\frac{3}{4}$ "	Note 3*
SA & SE-50 Sea Horse "16".....	21-452	Bronze	10"	10"	3	3 $\frac{3}{4}$ "	Note 4*
SA & SE-50 Sea Horse "16".....	21-525	Bronze	10"	12"	2	3 $\frac{3}{4}$ "	Note 3*
VA & VE-50 Sea Horse "32".....	23-39	Bronze	12"	12"	3	7 $\frac{7}{8}$ "	Note 1*
VE-50 Sea Horse "32".....	23-32	Bronze	12"	17"	2	7 $\frac{7}{8}$ "	Note 2*
VA & VE-50 Sea Horse "32".....	23-28	Bronze	12"	15"	2	7 $\frac{7}{8}$ "	Note 5*
VE-50 Sea Horse "32".....	23-38	Bronze	12"	13"	2	7 $\frac{7}{8}$ "	Note 3*
PA & PE-50 Sea Horse "24".....	23-39	Bronze	12"	12"	3	7 $\frac{7}{8}$ "	Note 1*
PE-50 Sea Horse "24".....	23-32	Bronze	12"	17"	2	7 $\frac{7}{8}$ "	Note 2*
PA & PE-50 Sea Horse "24".....	23-28	Bronze	12"	15"	2	7 $\frac{7}{8}$ "	Note 5*
PE-50 Sea Horse "24".....	23-38	Bronze	12"	13"	2	7 $\frac{7}{8}$ "	Note 3*
P-50 PA & PE-50 S. Horse "24".....	29-45	Bronze	12"	12"	2	7 $\frac{7}{8}$ "	Note 3*
SR-50 & 55 Sea Horse "16".....	21-286	Bronze	9"	15"	2	3 $\frac{3}{4}$ "	Note 5*
SR-50 & 55 Sea Horse "16".....	21-159	Bronze	9"	14"	2	3 $\frac{3}{4}$ "	Note 6*
SR-50 & 55 Sea Horse "16".....	21-287	Bronze	9"	16"	2	3 $\frac{3}{4}$ "	Note 2*
P-50 Sea Horse "24".....	23-39	Bronze	12"	12"	3	7 $\frac{7}{8}$ "	Note 1*
P-50 Sea Horse "24".....	23-28	Bronze	12"	15"	2	7 $\frac{7}{8}$ "	Note 6*
P-50 Sea Horse "24".....	23-38	Bronze	12"	13"	2	7 $\frac{7}{8}$ "	Note 3*
P-50 Sea Horse "24".....	23-126	Bronze	12"	10"	3	7 $\frac{7}{8}$ "	Note 4*
PR-50 and 55 Sea Horse "24".....	21-292	Bronze	10"	14"	2	3 $\frac{3}{4}$ "	Note 6*
PR-50 and 55 Sea Horse "24".....	21-179	Bronze	10"	17"	2	3 $\frac{3}{4}$ "	Note 5*
PR-50 and 55 Sea Horse "24".....	23-29	Bronze	10 $\frac{3}{8}$ "	18"	2	3 $\frac{3}{4}$ "	Note 2*
PR-50 and 55 Sea Horse "24".....	23-30	Bronze	10 $\frac{3}{8}$ "	19"	2	3 $\frac{3}{4}$ "	Note 7*
VR-50 and 55 Sea Horse "32".....	23-29	Bronze	10 $\frac{3}{8}$ "	18"	2	3 $\frac{3}{4}$ "	Note 5*
VR-50 and 55 Sea Horse "32".....	23-30	Bronze	10 $\frac{3}{8}$ "	19"	2	3 $\frac{3}{4}$ "	Note 2*
VR-50 and 55 Sea Horse "32".....	21-179	Bronze	10"	17"	2	3 $\frac{3}{4}$ "	Note 6*
VR-50 and 55 Sea Horse "32".....	23-37	Bronze	10"	20"	2	3 $\frac{3}{4}$ "	Note 7*
XR-55 Sea Horse "50".....	35-69	Alum. Bronze	10 $\frac{3}{4}$ "	20"	?	3 $\frac{3}{4}$ "	Note 7*

- *NOTE: 1. For Baby Buzz and other V-bottom medium fast boats. Supplied as regular equipment.
 2. For light weight racing boats sold as an accessory only.
 3. For light displacement boats—sold as an accessory only.
 4. For heavy displacement boats and small cruisers—sold as an accessory only.
 5. For medium weight racing boats—supplied as regular equipment.
 6. For heavy weight racing boats—sold as an accessory only.
 7. For exceptionally fast racing motors on exceptionally light racing boats.

INDEX

Attaching to Boat or Canoe (Square Sterns).....	6	Magneto Lever Works Loose	21
Attaching to Boats or Canoes (Pointed Sterns).....	7	Motor, Dropped Overboard..	31
Attaching to Extra Deep Boats	7	Motor Lubrication.....	10-11
Automatic Tilt	18	Motor Races	18-19
Backfiring	16	Oiling, High Speed Service....	11
Carbon in Motor.....	30	Oiling, Ordinary Service.....	10
Carburetor	12-15	Overboard-Motor	31
Care of Ignition.....	19	Propeller, Selection of.....	31-32-33
Care of Motor.....	28	Propeller Races or Slips.....	18-19
Care of Motors used in Salt Water	31	Pump	23
Cleaning Carburetor.....	17	Remove Magneto, To.....	21
Cold Motor.....	12	Return of Motor.....	2
Control Speed, To.....	17	Reversing	17
Cooling System, Pressure Vacuum	22-23	Reversing Lock Lubrication..	18
Description, General.....	6	Rope Steering	18
Draining Water Cooling Sys- tem	29	Serial Number, Motor.....	6
Exhaust Holes in Muffler.....	29	Service Stations and Distribu- tors	34-35
Flooded Motor.....	16	Shear Pins, Broken.....	19
Foreword	3	Shock Absorber.....	18
Full Pivot Steering.....	17	Slipping Propeller.....	19
Gasoline Tank Capacity.....	9	Slow Speed Running.....	17
Gears	22	Smoke from Muffler, Exces- sive	16
Gear Case Lubrication.....	11	Spark Plugs, Care of.....	19
Gears, Adjustment of.....	22	Spark Plugs, High Speed.....	19-20
Ignition Cables	27	Starting Motors (Models A and K-50)	28
Illustration, Sea Horse "12",	5	Starting Motors (Models J- 25, A-45 and K-45).....	12-13
Illustration, Sea Horse "16"	4	Starting Motors (Models S, SR, V, VR, P and PR	13-14-15
IMPORTANT NOTES		Stern Heights.....	9
Inside Front Cover		Steering, Full Pivot.....	17
Knocking	30	Stopping Motor.....	17
Lag Screw	7	Storing Motor	29
Landing	17	Taking Down Motor.....	28
Loss of Power.....	30	Tank, Gasoline	9
Lubrication Instructions	10-11	Warranty	2
Magneto	21	Water Drain.....	23
		Water Pump.....	23