

VOLUME 4

NUMBERS 1 & 2

APRIL 1969



THE ANTIQUE OUTBOARDER





THE ANTIQUE OUTBOARDER CONTENTS



April, 1969

Club Briefs	Page 2
Notes From The Curator	3
Twin Cities Chapter News	7
Outboard Racing Since 1945	10
Lake Hopatcong Meet	14
The Collector's Gallery	18
310 Senior Speedster	24
The KG-9, MK-40 and Us	25
Feature - Big Twin Johnson	27
Trader's Cove	32

Cover: A Model KD-15 9.8 HP Johnson on a light plywood runabout ruffles the calm surface of the Minnesota River at Mendota.

The Antique Outboarder

Volume 4 • No. 1 & 2

January - April, 1969

Published quarterly by the Antique Outboard Motor Club, Inc.
Publication Offices - 2316 W. 110th St., Bloomington, Minnesota 55431
Club Headquarters - 1107 Pueblo, Richardson, Texas 75080

Single copies: \$1.00 except as included with Club membership. Subscriptions: Nonmembers - \$4.00 per year
Change of address should be forwarded two weeks in advance and Zip code numbers should be included.

© A.O.M.C., Inc., 1969. All rights reserved.

The Antique Outboard Motor Club Inc. is incorporated in the State of Texas as an Educational Institution. The Club is devoted to people all over the world who are interested in the search for, restoration and preservation of old time outboard motors. Regular membership dues are \$7.00 per year. Other membership information available on request. Address membership requests to A.O.M.C., Inc., 1107 Pueblo, Richardson, Texas 75080.

Club officers, addresses and duties:

David R. Reinhartsen, President: 1107 Pueblo Drive, Richardson, Texas.
Coordinator of club activities.

Christopher R. Owen, Vice-President and Test Editor: Route 3, Eau Claire, Wisconsin. Runs lake tests of antique motors.

Robert Brautigam, Editor, The Antique Outboarder: 2316 West 110th Street, Bloomington, Minnesota 55431.

Marcus Wright, Parts Acquisition: 30 Crest Drive, Little Silver, New Jersey. Helps members find parts needed in their restoration projects.

John C. Harrison, Treasurer and Technical Advisor: 1000 N. W. 54th Street, Miami, Florida. Reviews financial reports and gives advice on motor restoration.

Carole R. Reinhartsen, Secretary: 1107 Pueblo Drive, Richardson, Texas. Keeps records, etc.

Richard A. Hawie, Curator: 31 Hillside Drive, Easton, Connecticut. Helps in identification of rare motors and prepares a column, Notes From The Curator.

W. J. Webb, Historian: 2560 North 97th Street, Wawatosa, Wisconsin. World's foremost authority on outboard history. Author of a column, Of Historical Interest.

James L. Smith, Special Features Editor: 330 O'Connor Drive, Toronto, Canada. Preparation of special articles on unusual motors.

Ray Machen, Membership Coordinator: 624 Gardner Road, Westchester, Illinois. Distribution of Club literature.

Robert Zippy, Classified Editor and Editor of The Newsletter: 24A St. Regis Street, East Hartford, Connecticut. Management of the classified section, and preparation of a monthly newsletter.

Bud Cowdry, Racing Editor: 48 Farm Street, Danbury, Connecticut. Preparation of a column on the early days of outboard racing.

Richard M. Jones, Membership Secretary: 20505 N. W. 3rd Avenue, Miami, Florida, 33169. Keeps membership records.

Bob Hampton, Motor Registration: 54 Clinton Avenue, Eatontown, New Jersey, 07724. Registration of Antique Outboards.

Lowell Simmons and Paul Aruda, Special Assistants: 1107 Pueblo, Richardson, Texas 75080.



CLUB BRIEFS

Beginning with this issue, The Antique Outboarder has a new editor. Regular contributors of articles, pictures and other data for publication in the magazine should send their material to R. W. Brautigam, 2316 W 110th Street, Minneapolis, Minnesota 55431. Please indicate if photos are to be returned and include captions for each. All members are urged to submit any items for publication that you think might be of interest to other readers.

Many thanks to TC Chapter member John Koonce who lost a good deal of sleep and donated much time to preparing the address labels and seeing to the "fine print" for this issue.

The regular mailing dates for the quarterly Outboarder are the first of January, April, July and October. All input from contributors should be received at least three weeks prior to mailing dates in order to be included.

Thanks to the efforts of Dave Reinhartsen and others, The Antique Outboard Motor Club is now incorporated -in the state of Texas- as an educational institution. The new club designation is AOMCI.

The club is interested in more members and a wider circulation of The Antique Outboarder. Don't overlook the possibility of giving a relative or friend a gift subscription to the magazine at Christmas time or for a birthday, etc. The rate is \$4.00 per year. Let the Editor know too of any ideas you have for selling advertising space in the magazine. A better Outboarder will result from having more dollars available.

Bob Zipp, Editor of the Newsletter, writes: "Several members have written telling me that they have not been receiving their copies of the club newsletter. The reason for this in one word is 'Argosy'. Publication of the newsletter has been temporarily suspended because of the deluge of mail resulting from the Argosy article. Since the Giant Twin panic of 1968 and the great Five Hundred Dollar Fever spread across the Nation last summer, I have processed and answered 753 letters plus or minus a few. And then as the Form 101's began pouring back, there were times when I thought there would be no end to it. So something had to give. Therefore, everyone on the club rolls should have received the September, 1968 issue of the Newsletter. This was the last one mailed. If there is a member in the club who would like to assume the office of Editor of The Newsletter, and work with Bill Kelly, he (or she) would be most welcomed for as the tidal wave starts receding from Trader's Cove, I doubt that my work load will be the same, as before the Argosy article. Right now I have two stuffed envelopes waiting to be processed."

Advise the Outboarder of any intended Club meets to be held mid-summer or after. Other members might be interested in attending.



RICHARD A. HAWIE

NOTES FROM THE CURATOR

I have finally gotten a close-up lens for my camera and hopefully we can add some pictures to my efforts. Since one picture is worth a thousand words, this article should contain 7000 words less than usual.

This time we will delve into the Koban motors. Bob Zipps is always after me for more Koban information; and Sam Vance and Bill Jones have turned up Kobans that they need information on. I did not check with Bob Hampton to see how many Kobans are presently in the Club; but the last population listing a year or so ago listed seven. Three of the seven were mine so this may not be the most popular article to appear.

Remember this is not an in depth study. In fact, I haven't even torn all three of my Kobans down. Restoration is not my strong point. On to a little history and identification of Koban.

If you have Jim Webb's book, you know that Kobans were made from 1914-1926 when the Evinrude Company bought the outboard line from Koban. If you haven't Jim's book, why haven't you?

The name Koban was a contraction of the names Koch and Banon who were the owners. Koban was one of the first to produce a twin cylinder opposed piston engine. I believe that all of the models that they made were twins and used rudder steering.

I have a copy of one of the Koban catalogs, and the first paragraph reads "The Koban was the first rowboat motor made with two cylinders, and in many important respects differs widely from all other detachable rowboat motors. It has back of it four years of unparalleled success--thousands of Kobans now being in use in every part of the civilized world." Since this catalog was undated, I at first thought it must be a 1918 edition since the company was started in 1914; however, the ads in the boating magazines would seem to indicate that this is a 1917 edition, and that their "four years of unparalleled success" is an ad man's four years.

It is, of course, risky to identify motors relying solely on advertising pictures because the actual motors were sometimes changed a little while the advertising cut was too often used throughout the year. When we are dealing with obscure brands that is what we have to do. Please keep in mind that this Koban data is gleaned (my wife is humming "Bringing In The Sheaves" as I type) from ads and the powers of deduction. I know I sound like a politician before election, but I have in mind a 1929 Elto ad which is

very confusing. This Elto ad has an artist's drawing of the 1929 Quad; and if you look closely at the drawing, you will see what looks like one single butterfly valve carburetor on a manifold having two branches, one to each crankcase. This would indicate possibly a three port or rotary valve engine. The 1929 Quad had dual poppet valve carburetors, and the ads later in the year had photographs of the motor as it was produced. Suppose that Elto had been as obscure a motor as Koban -- with few motors and little data surviving? I am afraid that I would think that the 1929 Quad was a single carburetor model. I hope that a letter to Jim Webb will clear up this Elto art mystery. I think that it points up the fact that relying on ads and artwork may not be 100% accurate.

The Kobans were not the most successful motors; and compared to the Johnson "Waterbug" and the Elto "Rudder Twins" of the early 1920's, they were massive and archaic.

There were several features that were interesting. The Koban may not have been the first, but as far as I can recall, it was the only motor made with detachable cylinder heads until 1929 when Johnson models V and S were made. All other motors which I am familiar with had the cylinder and head cast in one piece. I won't get into any discussion of the merits of the two methods, but a detachable cylinder head was certainly an unusual feature during the years that Kobans were built. Does anyone know of any other motor which had detachable cylinder heads before the 1929 Johnson V's and S's?

The cylinder heads were interesting in themselves. The 1914 models had finned heads like the modern air-cooled lawnmower motors. The fins were not as deep as an air-cooled motor. The first picture is of the 1914 model. The fins, perhaps ribs would be a better word, can be seen. This ribbed cylinder head was pictured only in 1914. I have seen pictures of one so I am sure one still exists.



2



1



3

The next two pictures are of the cylinder heads from a 1915-1919 era Koban. The name was cast into the aluminum cylinder head. No provision was made for water cooling the head. The cylinder itself was water-cooled. Turn the head over as in #3 and "voila" an

aluminum head with hemispherical combustion chamber, and on a pre-1920 motor. Did someone say Chrysler Hemihead? I don't know if the 1914 ribbed head had a hemispherical combustion chamber or not.

The 1915-1919 Kobans were interesting because the power head was cast in one piece. Both cylinders and the crankcase were cast enblock. The top and bottom crankshaft bearings were end plates for the crankcase. The next three pictures show motors of this era.

Number 4 is of the 1915 model. Notice the underwater exhaust tube just above the rudder. This is a magneto model. The carburetor is an "airfloat feed" type and is on the port cylinder. A passage was cast from the carburetor opening to the center of the crankcase.

WITHOUT AN EQUAL

The World's Greatest Rowboat Motor

Built on different lines. Has two cylinder principle which does away with vibration.

It does not shake the boat.



4

SPEED!



6

Number 5 is of a 1917 model D. The carburetor is mounted on the center of the crankcase. It is a poppet valve type. There is no underwater exhaust tube. This could be ordered extra, when buying the motor, for \$5.00! This motor had magneto ignition. There was also a battery ignition model D. The 1917 catalog also pictures a model C made with battery ignition only. This model C had an "airfloat feed" carburetor on the port cylinder. It looked like the 1915 model in picture #4 except that it had battery ignition. I would guess that they were trying to get rid of some back inventory. The model D was finished in pearl gray and was supposed to reverse with the pressing of a button, but the catalog doesn't explain how.

"It starts so easily that it is not even fitted with a cranking handle. Note that all others have a cranking handle." So says the 1917 catalog. Picture #6 is of the 1918 model. Standing up on top of the redesigned flywheel is a cranking handle which they said that they did not need in 1917! So much for an ad man's integrity; it was not much better then than it is now.

The 1918 model looked like the 1917 model except for the new flywheel. Koban used the same cutout for their ads in 1919 as they did in 1918.

The third basic model group was made in 1920 and carried through to 1926 when Evinrude bought them. Picture #7 is of the 1920 model. It looks like the 1919 model, but look at the crankcase and you can see that the 1920 model has detachable cylinders. The bore and stroke of all the Kobans I have found listed was 2 5/8 bore and 2 3/8 stroke, 3 HP at 900 RPM. The 1920-1926 versions had much larger cylinder castings, but the bore was still 2 5/8. The outside diameter of the 1915-1919 models was about 4 1/16 inches while the outside diameter of the 1920-1926 models was about 4 1/2 inches. One half an inch is very noticeable when it is a difference in diameters. The water passages were larger and a lot more iron was cast on the cylinder walls.

I don't know if Evinrude Company sold any Kobans after they bought the company or not. The impression I get is that parts, sales and service for Kobans was probably provided, or at least hoped for, by the Evinrude Company. I think it is fair to say that Koban was bought and buried.

It is interesting that none of the unique features of Koban were adopted by Evinrude. The detachable cylinder head feature was not a characteristic feature of the Evinrude-Elto line before 1940.

Koban just faded into the sunset as we will do also. Next time we will try to picture some of the Johnson features mentioned last time, and we will see what may come up in the next month or so.

- 1 -- March, 1914 MOTOR BOATING p. 89
- 2 & 3 -- my 1918-1919 Koban
- 4 -- May, 1915 RUDDER p. 239
- 5 -- Feb., 1917 MOTOR BOATING p. 82
- 6 -- June, 1918 MOTOR BOATING p. 70
- 7 -- July, 1920 MOTOR BOATING p. 67

A PLACE TO VISIT ---

Near the town of Jensen Beach, Florida about 40 miles north of West Palm Beach is an exotic polynesian restaurant called "The Outrigger". Located on the Indian River, the restaurant is operated in connection with a marina. The owner is Frances Langford who, I understand, married into the Evinrude family. Moored at the marina dock is the Evinrude yacht "Chanticleer" - a craft of fine proportion approximately 125 feet long and complete with radar. Alas - under the fantail there's no sign of an outboard motor. However, the dinghy is powered by what appears to be a 55 HP model; and hanging from the ceiling of The Outrigger is a native canoe with a small 3 or so HP Evinrude mounted astern. Good atmosphere for boating fans!

7





TWIN CITIES CHAPTER NEWS

MINNESOTA

BOB BRAUTIGAM

There's a swinging new group in the Twin Cities known as the Twin Cities Chapter of the AOMC. Our enthusiasm comes natural and our working stock comes from a thousand or more marine shops, back sheds, basements and second hand stores. We're not real sure just what it is we're dedicated to, but we aim to have a little fun, further the cause of old outboards and increase the club membership.

In October, 1968, the charter meeting of the Chapter was held at the home of the writer. Initial members and elected officers were: Ron Johnson, President; John Koonce, Secretary-Treasurer; and Bob Brautigam, Reporter. Our first business discussion included plans for regular monthly meetings, identification work, motor hunting, restoration, soliciting new members and possible displays.

We expect our closer chapter association will provide each of us more enjoyment of outboarding and permit a better organized response to the National Club activities. With due respect to these noble ideas, it's great to see each other's collections, compare notes and swap stories. Who else but an AOMC member would appreciate why I drove the family from Minneapolis to Utica, New York to haul home five dirty old motors - or why a fellow can spend most of an afternoon prowling in the 3 foot high grass behind a blacksmith shop looking for motor parts "thrown out there somewhere about 5 years ago?"

I guess most collectors have run into unique or humorous situations while motor hunting. I recall over two years ago buying a 1927 model 72T Lockwood from a motor shop in St. Paul. Then about a year ago, I bought another 72T Lockwood from a gentleman living fifty miles west of St. Paul. As I wrote down the serial number in my record book, I discovered that my new find, number 8196, was one digit removed from my earlier motor, number 8197. These two machines built side by side and separated for forty years, now hang side by side once more.

In November, the Chapter met at the home of Ron Johnson where we added a new member, Dave Johnson to the rolls. Our thanks to Ron's wife who served lunch highlighted by a cake with an outboard motor designed into the frosting. None of us patriots could bear to eat that part of the cake. I understand Ron puts that piece under his pillow each nite hoping he'll have better luck finding old motors.

Chapter president Johnson is an electrician by trade and comes by his interest in motors honestly. His parents own Johnson's Rippleside Resort on

Ripple Lake near Aitken, Minnesota. Ron keeps a Chriscraft plywood run-about at the resort where he does much of his motor running. Ron's favorites are the larger, faster motors and his pride and joy is a 1941 model 17.4 H.P. Sportfour Evinrude.

The Sportfour is a quad weighing about 98 pounds and priced in 1941 at \$255.00. Ron bought his from a neighbor at the resort for about 95% discount. Even after hanging in a barn for more than 10 years, the motor needed only new spark wires to make it run like new. I can testify to its speed - I watched him fly by me on Prior Lake this past summer.

Ron keeps some of his motors in his basement where he also has his shop. His wife says he spends hardly no time at all down there. The president's collection, as it's called, includes Johnson models J-65, PO-15, OK-55, A-35, and OA-65; the Evinrude Sportfour and 1929 14hp Fastwin models; a 1929 Elto Speedster; a 1935 A Model Champion; a 1933 Motorgo by Muncie and a few he hasn't shown off yet.



President Johnson with the three little Johnsons and a classic '29 Elto Speedster.



Ron again with his 22 hp Johnson and his favorite, the '41 Sportfour.

Service Tips -

Hard starting on the 1910 Looseroed Single was usually remedied by removing the spark plug and adding a tablespoon of Ether to the cylinder. This is how the term "knuckle-buster" originated and explains why one sees so few 1910 Looseroed Singles these days.



Typical scene in the Brautigam basement. From left to right on the front rack, a 1932 Evinrude Sturdtwin, a 1939 Neptune 1.2 hp, a 1915 Evinrude and a Circa 1918 Model K Serial 1315 Evinrude. None of my Evinrude I. D. data admits to a model K, but there it is.



More units in moth balls. These are part of about 35 restored motors in what used to be the family room. In the front, left is a 1930 model OB-2 Neptune. The signs and decals pep up the appearance even though artistic license is sometimes taken.

OUTBOARD RACING SINCE 1945

BY

RAY LUCAS JR

Ray Lucas at 65 MPH
with Johnson PR-65
Richmond, Virginia, 1953

Some of the most remarkable outboards ever built were the racing engines produced by Johnson and Evinrude. I am sure not many people realize just how long these engines were competitive. Evinrude ceased production at the beginning of World War II, and Johnson stopped production several years before that. Yet, it has been only a very few years that if you wanted to win races there was no substitute for one of these engines.

My own racing career began in 1949 and extended ten years from that date. All but the first year was spent campaigning a PR-65, and that year was spent driving an Evinrude Midget. I will, therefore, largely confine my reminiscences to class C. In the years immediately following the war these already old racing engines commanded unbelievable prices. A C that was barely competitive (about 59-60 MPH) could be had for less than seven or eight hundred dollars, and that was when money was worth much more than it is now. If someone winning the Nationals could be persuaded to sell at all, two thousand dollars was not completely unheard of.

Besides the fact that engines were expensive it was not always possible to get a good one at any price. The best thing to do in these circumstances would be to employ the services of Marshall Eldredge -- if you could get them. Eldredge would take what you had and for about three hundred dollars plus parts get it going. Many drivers were constantly looking for "secrets" which made the winners go. There were, of course, no secrets; just a lot of machine shop know-how and the ambition to put it in practice was what created the fast motors. Of course, the engines were modified to some extent. They were ported, rotary valves were retimed, etc., but everyone knew about this. In any case, going racing in those days was both expensive and difficult to do.

Things soon got a little better, however. Several people started making parts for the old motors. Randolph Hubbell eventually produced enough SR



and PR replacements to construct new engines, which he did and offered them for sale. This was in the early fifties and if my memory serves me correctly, they sold for something in the neighborhood of five hundred dollars. Also, Pete Stampfel made stern brackets and other items, Fuller made rotary valves and rod roller retainers, Jones and Vincent made cylinders, Flannagan made crankshafts, and Wiseman made pistons. Hubbell is the only one still in the outboard business to my knowledge. His address is 2511 N. Rosemead, S. El Monte, California, and as far as I know, he still has just about everything.

Speeds continued to climb for all classes until the German Konig and British Anzani truly made the Johnsons and Evinrudes obsolete. The APBA one mile C hydroplane record was 63.549 in 1949. This record was set in 1945 however. In 1957 the C record had gone up to 73.566 and was set by an Evinrude. This record incidentally, stands today. This is somewhat misleading, however, since the current C kilometer record is 94.830 held by a Konig. It just seems that no one is interested in trying for the mile record since it is very hard on equipment. Nevertheless, a gain of ten MPH without any basic change in engines adequately demonstrates the potential these old racing engines possessed.

It was at the 1957 Nationals that the foreign engines became plentiful and began to write the end of the story for the Johnsons and Evinrudes. Although they did not start getting into the record book for two or three years, their superiority (in speed if not dependability) was evident. The current U.I.M. C record is over 100 MPH.

With really new racing engines once again available, all worthwhile efforts on the Johnsons and Evinrudes came to a halt. It was obvious that a Konig or Anzani was necessary to win in serious racing. I will never believe that the entire potential had been tapped in the PR-65, however. Much of the

fantastic speed in current class C racing reflects improvements in boat, lower unit and propeller design which came after the PR was given up as hopeless. Also, much has been learned since then about ignition and tuned exhausts. Of course, it would be idle to suggest that a PR-65 could ever go as fast as a VC Konig, but it would be interesting to see how fast one could be made to go by using what we now know, short of changing the actual engine design. 80 MPH would not be too hard to believe. And this engine design is at least 35 years old.

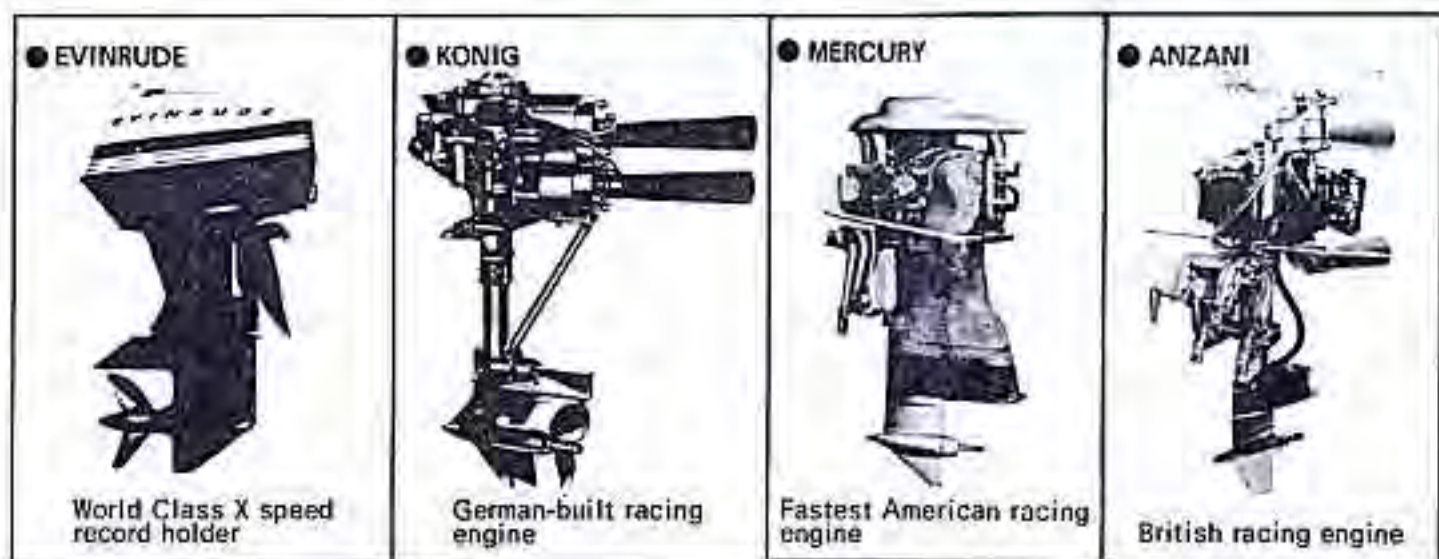

The general character of outboard racing has changed quite a bit in the past ten years in ways other than faster speeds. The new engines with light flywheels and not much low end torque must be held completely free of the water to be started. You need a pit crew of at least two good men to accomplish this feat. One man stands on either side of the engine and lifts the entire stern so that the propeller clears the water. The driver is in the boat during this exercise, and when the propeller is free he cranks. When the engine starts it is allowed to scream a few seconds and then the boat is dropped into the water. This makes for some spectacular pit scenes, but it is fairly hard on the pit crew. On the other hand, any of the old timers could easily be started in the water. You simply cranked, putted away about ten yards and then the power came on and away you went.

In class C racing of the past, if something went wrong with the engine, it was usually one of three things: a stuck or burned piston or broken roller retainers. Of course, if the engine was set up properly, these ailments were fairly infrequent. A stuck piston at 60 MPH felt like slamming on the brakes in a car. Then there were some of the more spectacular occurrences of stuck pistons. I saw a C win a race one time, and in the excitement the driver completely backed off the throttle as he crossed the finish line. This, of course, cuts off the fuel and hence all lubrication in a two cycle engine. He had to be towed in even though he won the race. I have also heard the story many times of Clint Ferguson "sticking up" while trying to raise his own class X record. According to reports he had been one way through the traps at about 90 MPH. On the return run he stuck a piston. At that speed Clint kept going with the steering wheel and part of the deck in his hands. This supposedly took place about 1939 or 1940.

Even though speeds are much higher today in the outboards, I do not think it is nearly the sport it once was. This is mainly because there simply are not many boats at any race. Fields of four or five boats are common today. This is unfortunate, but it perhaps will improve.



Possibly the first organized outboard race in the United States. The regatta was sponsored by the Pewaukee Yacht Club during the summer of 1911, and held on Pewaukee Lake in Wisconsin.

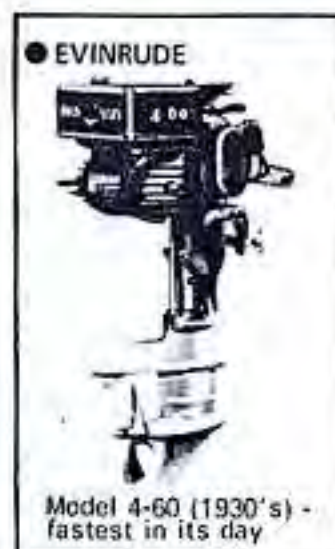
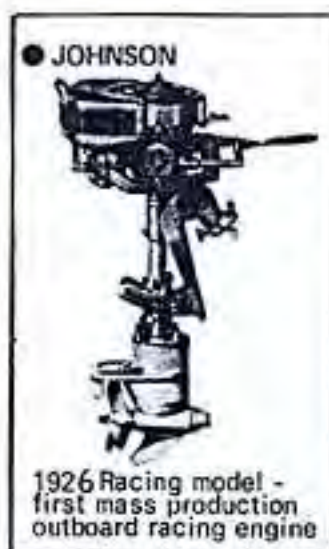
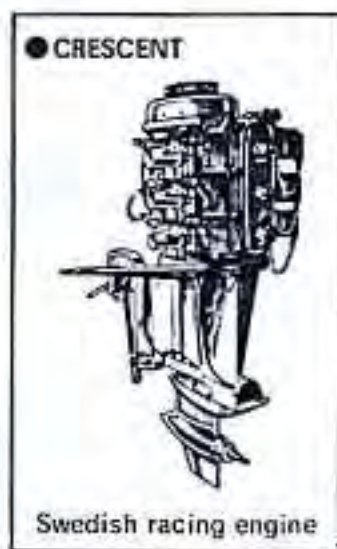



Lake

HOPATCONG



THE LAKE HOPATCONG ANTIQUE OUTBOARD MOTOR REGATTA

by Tom Luce

Compared to most of the drab scenery along New Jersey's super highways Lake Hopatcong is unbelievably beautiful. It is New Jersey's largest lake, nine miles long with 63 miles of shoreline.

The Lake has been "discovered" by boatmen. During an average summer season more than 15,000 powerboats are registered! And this figure excludes the sailboats, rowboats, canoes, kayaks, and antiques that venture forth to test their skipper's skills in navigating the shore to shore chaos of powerboat wakes. Things become a little less hectic, though, after Labor Day when Bikini-clad water skiers become less numerous, the wakes subside and the surviving fish begin to come out of hiding.

In keeping with this lower level of lake activity, Dr. Craver and I anticipated a quiet, informal outboard meet on September 14th. We expected that perhaps a dozen members would attend.

We were favored with perfect weather, and midway through that Saturday morning we tore up our schedule of activities. Members, their families and friends, and visitors poured into Len E's Pagoda parking lot. The influx didn't slow down until about noon when 24 members had registered with almost 100 antique outboard motors. This was enough to make the Regatta the largest meeting of club members yet to be held anywhere.

The "board of directors" held a hasty meeting. We decided to postpone our auction, shorten the welcoming "speeches", and to hold the water-based activities immediately after lunch.

A 14-boat armada popped, chugged and lurched away from the docks to await the starting signal for the first event, a modified predicted log contest. What an experience it was to see 14 craft powered by antique outboards, mostly all running at the same time! What excitement to see them dodging each other in the small holding area! It is a credit to the boat handling abilities of our members that there were no mishaps.

All participants had previously handed over their watches and guessed how long it would take them to travel to the race course marker and back (distance unknown). After the smoke had cleared, it was discovered that John Jensen had won the contest with an error of only 5 seconds.

Eighteen antiques were then signed up for the Bang and Go Back Race. The fleet was divided in half according to horsepower, and two preliminary heats were held. The two best from each heat then "raced" for the hardware. It was a real photo finish when Mark Wright's boat powered by his Indian Arrow roared past Bob Zipp's at the last possible instant to win by the length of a shear pin.

Ken Hampton's and Vince Lentine's activities during the Bang and Go Back Races cannot be ignored. Ken Hampton very nearly swallowed the pipe he was smoking when his Elto's high tension wire broke loose and grounded to his aluminum boat. Vince Lentine gets credit for entering the smallest motor on the largest boat. At the starting signal his 17 foot Glastron runabout, which was "propelled" by a 1-1/2 H. P. Elto Ace sharing the transom with an idle Evinrude X-115, was heading exactly 180° away from the course marker. Wrongway Vince managed to swing his craft about against the drag of the X-115 just in time to see the winner cross the finish line.

Buddy Streat, winner of the last two Long Branch, N. J. trophies for the oldest running motor category, finally got some competition from Mark Wright. Mark's 1913 Evinrude completed the course without missing a beat.

Buddy still managed a visit to the trophy table. His superbly restored 1922 Caille Liberty Single took top honors in the mint condition judging. Anthony Caglione's English Villers was judged the most unusual motor at the Regatta and he joined John Jensen, Mark Wright and Buddy Streat at the trophy presentations.

As with the fellow who said he was "working on his second million dollars" (he gave up on the first), it is time for Dr. Craver and myself to stop thinking about the first, and start planning the Second Annual Lake Hopatcong Antique Outboard Motor Regatta. We would like to take this opportunity to thank all of you that came and contributed towards the success of this First Regatta. We hope to see you again next year.

REGATTA SUMMARY

Results of Contests and Judging

Predicted Log	1st Place	John Jensen	1929 K-45 Johnson
	2nd Place	Vince Lentine	A-70 Johnson
Bang and Go Back Races	1st Place	Mark Wright	1930 Indian Arrow
	2nd Place	Bob Zipps	1939 LT-39 Johnson
Oldest Motors to Complete course	1st Place	Mark Wright	1913 Evinrude 'A'
	2nd Place	Buddy Streat	1917 Caille 5-speed
Mint condition		Buddy Streat	1922 Caille Liberty single
Most Unusual Engine		Anthony Caglione	Villers

Twenty-four Registered Members

Harry Bickel, Pottstown, Pa.	Vince Lentine, Flemington, N. J.
Anthony Caglione, Dover, N. J.	Vincent Loss, Levittown, N. Y.
Dr. Lloyd C. Craver, Lk. Hopatcong, N. J.	Tom Luce, Summit, N. J.
Stan DuBois, New York, N. Y.	Curt Reed, Berwyn, Pa.
Ken Hampton, Eatontown, N. J.	Dave Reinhartsen, Richardson, Tex.
Bob Hampton, Eatontown, N. J.	Carl Sedell, Washington, D. C.
Richard Hawie, Easton, Conn.	Frank Shimer, Bellmore, N. Y.
Harry Holden, Groton, Conn.	Buddy Streat, Richmond, Va.
Peter Hunn, Simsbury, Conn.	Bob Thornton, Chevy Chase, Md.
John Jensen, Fords, N. J.	Sam Vance, Unadilla, N. Y.
Phil Kranz, Altamont, N. J.	Mark Wright, Little Silver, N. J.
Sal Lentine, Flemington, N. J.	Bob Zipps, East Hartford, Conn.

Organization and Credits

Organizers: Tom Luce and Dr. Lloyd C. Craver

Special Assistant: Ray Sabia

Advisors: Mark Weight and Dave Reinhartsen

Registrars: Jean Luce and Nancy Wright

Official Photographer: Harry Bickel

N. J. Marine Police Sanction and Patrol: Chief William Fennecken and Officer Dick Bruckler

Distinguished Visitors: Hopatcong Major Martin Murphy; W. Chaplin Condit, retired automotive engineer, Sun Oil Co.; and Fred Jacoby, internationally known outboard racer.

Contributors: Many thanks to Len Eisenstein, Len E's Pagoda, who generously donated the use of his fine facilities including his 41-boat rental fleet; to Solar Oil Company for the case of Sunoco outboard oil; to Sal Lentine for the floating key chains; to Ken Hampton and the New Jersey Bell Telephone Company for the first aid kits.



Frank Shimer gets help.....



Marcus Wright and his daughter running a Silver Arrow made by the Indian Company



Trophy winners Anthony Caglione, Marcus Wright (2), Buddy Streat and John Jensen



Buddy Streat's 1934 Pigeon, Bob Thornton and Mayor Martin Murphy

THE ANTIQUE OUTBOARDER

Presents

THE
Collector's
GALLERY

FEATURING

OUTBOARD *MERCURY* MOTORS

KIEKHAEFER CORP., CEDARBURG, WIS.

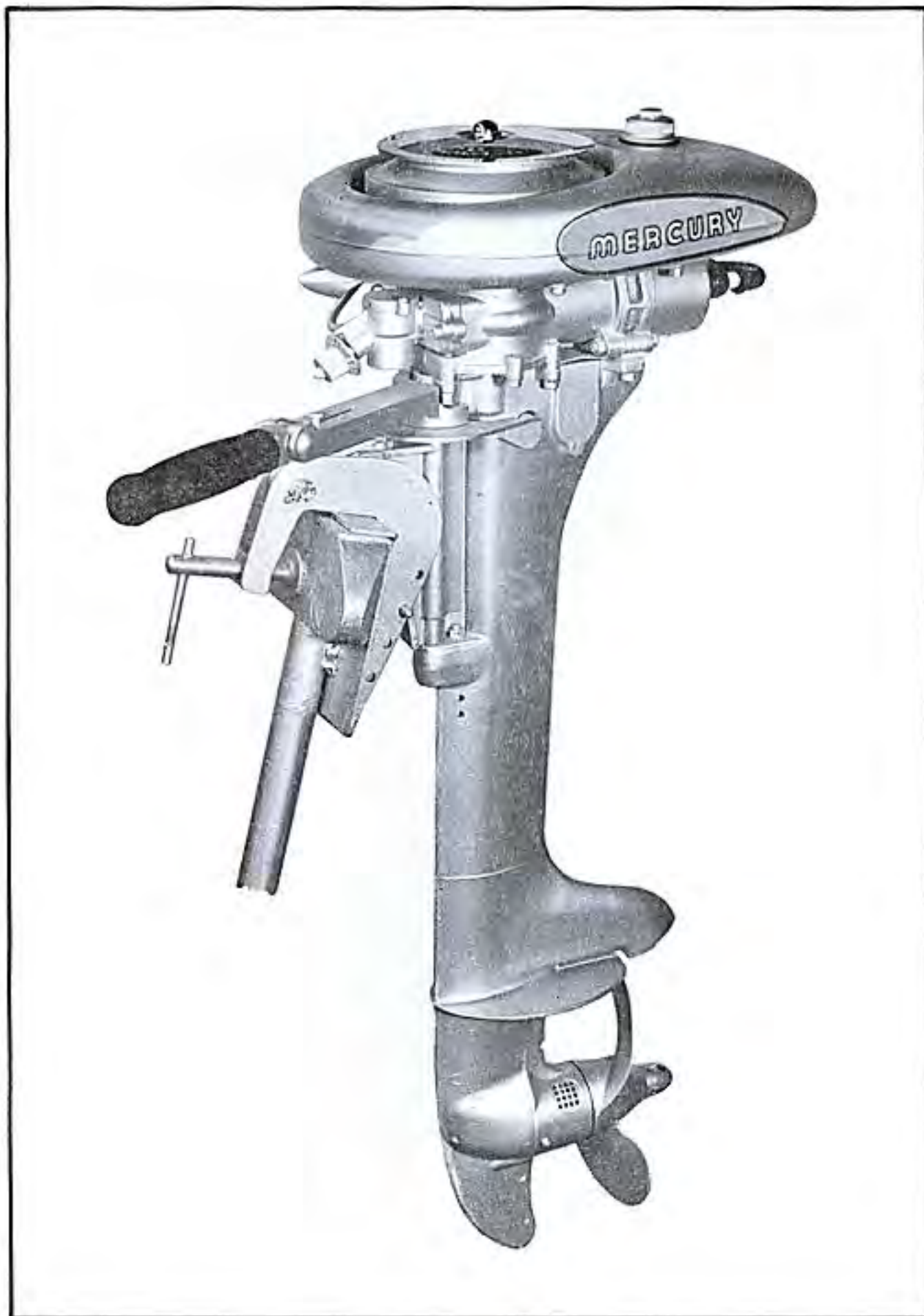

1940 MERCURY "STANDARD"
MODEL K2, 3 HP SINGLE





1940 MERCURY "STREAMLINER"
MODEL K3, 3 HP DELUXE SINGLE

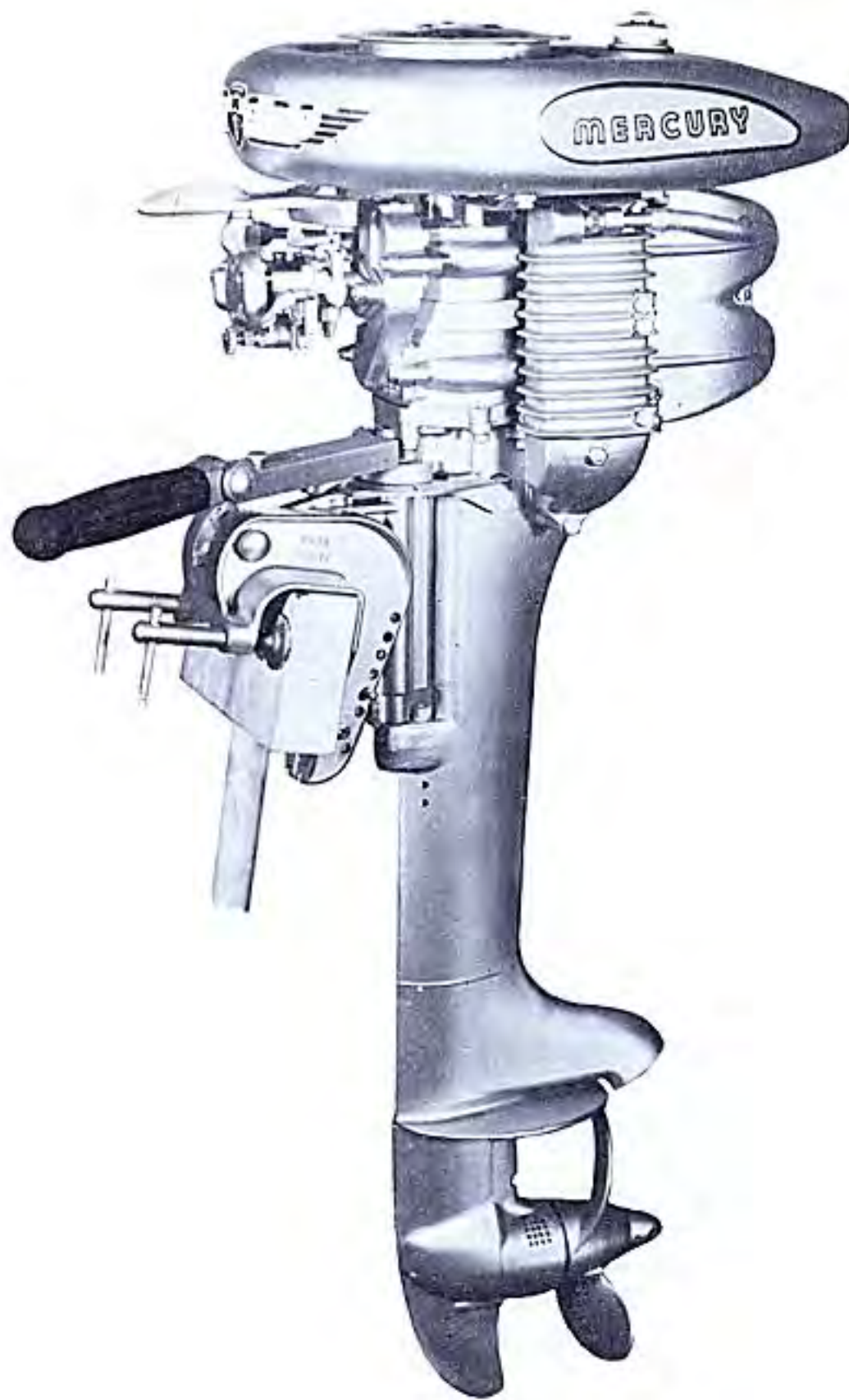

1940 MERCURY "ALTERNATE"
MODEL K4, 6 HP TWIN

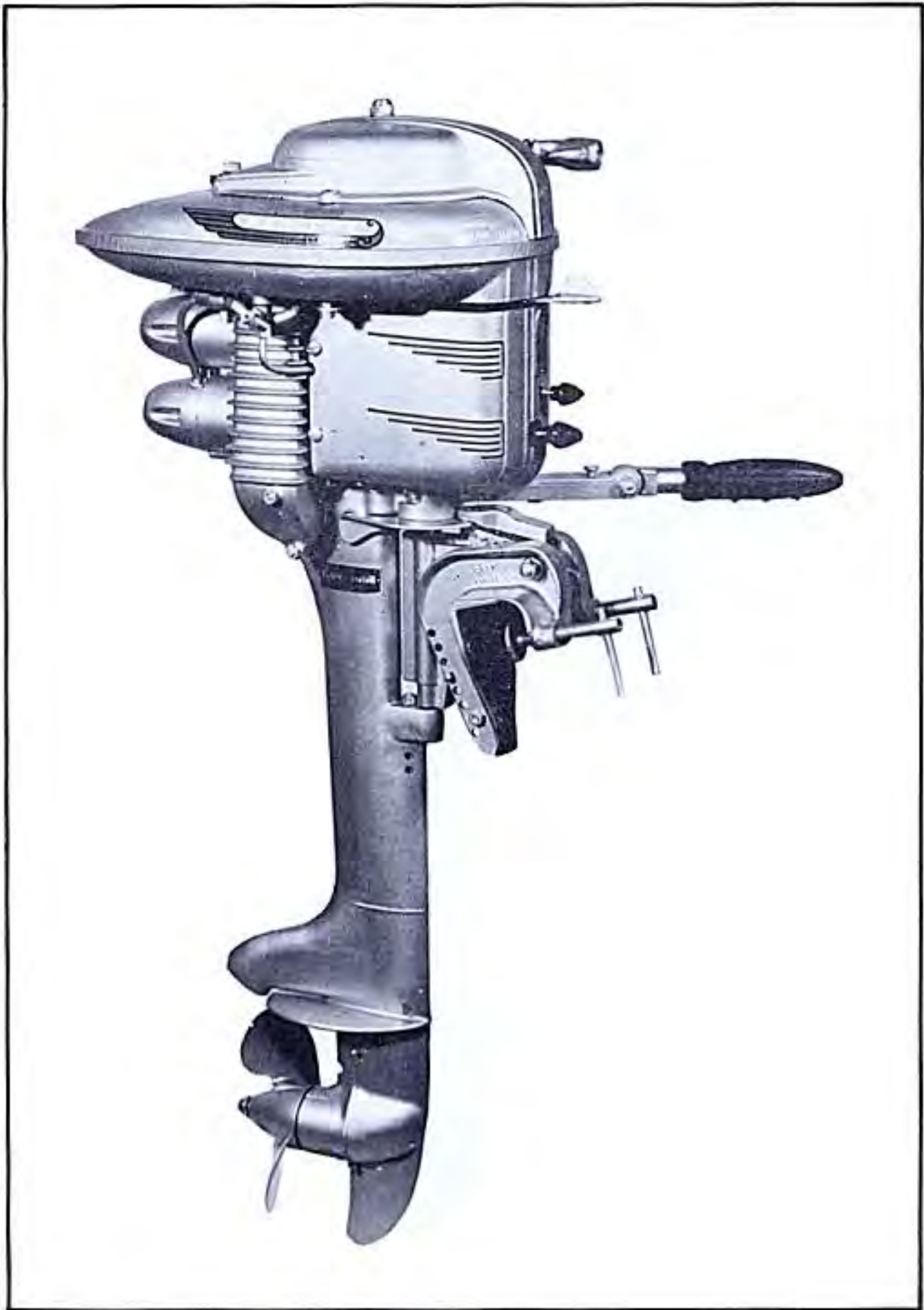

1946 MERCURY "ROCKET"
MODEL KD4, 6 HP TWIN

KIEKHAEFER MERCURY OUTBOARDS, 1940 to 1949

Designation	Model	Year	Spark Plug Model	Spark Plug Setting	Magneto Model	Breaker Setting	Horse Power	RPM	Bore	Stroke	Cu. In. Displ.	Engine Weight
Special.....	K1	1940	Ch. J-8J	.025	Eisemann	.018	2.5	3800	2"	1 3/4"	5.5	27
Standard.....	K2	1940	Ch. J-8J	.025	Eisemann	.018	3	4250	2"	1 3/4"	5.5	28
Deluxe.....	K3	1940	Ch. J-8J	.025	Eisemann	.018	3	4250	2"	1 3/4"	5.5	31
Alternate.....	K4	1940	Ch. J-8J	.025	Eisemann	.018	6	4250	2"	1 3/4"	11	41
Alternate Deluxe.....	K5	1940	Ch. J-8J	.025	Eisemann	.018	6	4250	2"	1 3/4"	11	43
Comet.....	KB1	1941	Ch. J-8J	.025	Eisemann	.018	2.9	4000	2"	1 3/4"	5.5	31
Comet Deluxe.....	KB1A	1941	Ch. J-8J	.025	Eisemann	.018	3.1	4000	2"	1 3/4"	5.5	32
Streamliner.....	KB2	1941	Ch. J-8J	.025	Eisemann	.018	3.2	4000	2"	1 3/4"	5.5	32
Torpedo.....	KB3	1941-42	Ch. J-8J	.025	Wico	.018	3.2	4000	2"	1 3/4"	5.5	36
Rocket.....	KB4	1941-42	Ch. J-8J	.025	Eisemann	.018	5.8	4000	2"	1 3/4"	11	42
Rocket Deluxe.....	KB5	1941	Ch. J-8J	.025	Eisemann	.018	6	4000	2"	1 3/4"	11	46
Rocket.....	KB4-1	1946	Ch. J-8J	.025	Eisemann	.018	6	4000	2"	1 3/4"	11	42
Comet.....	KD3	1946-47	Ch. J-8J	.025	Scia.-Eise.	.018	3.3	4000	2"	1 3/4"	5.5	32
Rocket.....	KD4	1946-47	Ch. J-7J	.025	Scia.-Eise.	.018	6	4000	2"	1 3/4"	11	42
Comet.....	KD3S	1947	Ch. J-8J	.025	Scia.-Eise.	.018	3.2	4000	2"	1 3/4"	5.5	36
Rocket.....	KD4S	1947	Ch. J-7J	.025	Scia.-Eise.	.018	6	4000	2"	1 3/4"	11	46
Comet Deluxe.....	KE3	1947-48	Ch. J-7J	.025	Scintilla	.018	3.6	4000	2"	1 3/4"	5.5	36
Rocket Deluxe.....	KE4	1947-52	Ch. J-7J	.025	Phelon	.018	7.5	4000	2"	1 3/4"	11	54
Rocket Deluxe.....	KE4A	1947	Ch. J-7J	.025	Scintilla	.018	6	4000	2"	1 3/4"	11	54
Lightning Deluxe.....	KE7	1947-49	Ch. J-7J	.025	Scintilla	.018	10	4000	2 1/8"	2 1/8"	19.8	59
Comet.....	KF2	1949-50	Ch. J-7J	.025	Phelon	.018	3.5	4000	2"	1 3/4"	5.5	38
Comet.....	KF3	1949-50	Ch. J-7J	.025	Scintilla	.018	3.5	4000	2"	1 3/4"	5.5	38
Super 10.....	KF7	1949-50	Ch. J-7J	.025	Scintilla	.018	10	4000	2 1/8"	2 1/8"	19.8	61
Super 5.....	KF5	1949-52	Ch. J-7J	.025	Phelon	.018	5	4200	1 3/4"	1 1/2"	7.2	41
Super 5.....	KF5	1949-52	Ch. J-7J	.025	Scintilla	.018	5	4200	1 3/4"	1 1/2"	7.2	41
Thunderbolt.....	KF9	1949-50	Ch. J-7J	.025	F.-Morse	.010 + .000 - .002	25 + *	"	2 3/8"	2 3/8"	39.6	122

All models use Kiekhaefer Quicksilver 2-cycle engine oil, 3/8 pt. mixed with each gallon of gasoline. Quicksilver models require 3/4 pint oil mixed per gallon. All models use Kiekhaefer Aeromarine Gear Lubricant in lower unit.

MODEL
310

SENIOR Speedster

An antique ELTO and the Club team up
to make a boyhood dream come true

When I was a young boy, we lived during the summers in our beach house in Wnem Beach, Washington. From the time I can remember, I was always fascinated with boats and out-board motors. Sitting on the beach, I could tell by the sound who was running his motor and how big it was. I was fascinated with the square tanks - and the bigger the tank - the faster it was - to me.

My father had several motors in storage, and all needing parts. It was just after the war, and parts were still hard to get. I wanted my father to get a 22 HP or larger motor and always hounded him about it, and finally before the summer of 1946, he promised me a big surprise.

One day, standing on the boathouse rail, I heard a motor that sounded like no other I had ever heard. As the boat came closer - I saw it was my dad - and our big motor. And a fine motor it was - a 14 HP 310 Elto Senior Speedster. The knob on the flywheel made it very unique, and it looked every bit as fast as any motor I had ever seen.

We borrowed our neighbor's 10 foot sea sled that summer, and we water skied and used a surfboard behind it. It was a perfect match, as the sea sled was light, and on the straight-away it would reach an exciting speed, but you had to watch the turns a little.

We ran the Speedster for two summers, and put a few 22's to shame, and then towards the end, a friend of my dad was skiing one afternoon, and Dad made a sharp right hand turn - too sharp - it flipped - and boat and motor and Dad and batteries went in all directions! Dad was not hurt, but the salt water had taken its toll, and it was the end of the Senior Speedster.

Years afterwards I often thought of that old motor, and made up my mind to find one someday.

Soon after joining the AOMC, I saw an ad in the Outboarder. There it was - a 310 Senior Speedster! I wrote, and proceeded to buy it. It was in excellent condition. After 21 years, I had found my Senior Speedster! This motor, and then others, started a trend, and now - in the back of the house, and along the side of the carport, stands a barrel - a very modest test tank.

On Sunday afternoons, my cheering section gathers - all the neighbor kids and my 6 - and I proceed to start these old antiques. As a motor starts - sputters and backfires, and then runs - spraying water all over, the kids yell and jump up and down. When the motor dies, they yell for more! What a rooting section! If a stranger in our neighborhood was to inquire where I live, my neighbor would reply - "Just go down 6th Street slow until you hear the damndest racked you ever heard, kids yelling and some damn fool out there starting motors - that's it" - that's where I live.

THE KG-9, MK-40 AND US

Stan DuBois

As you may have guessed by the title, the participation in the old outboard hobby is a family affair. I am the only antique buff in the family; the rest just enjoy boating and related sports, - skiing, etc. There are four of us, - my wife Vera, my son Robert, and teen-age daughter Kathy.

We don't live on the water, so we have tied the hobby in with our vacations and with visits to many delightful places throughout the United States. On our trips we camp out, and camping is a great sport in itself. Most lakes have camp sites, some are private, some state-operated, the rest are federal-owned. All have running water and bathrooms; some even have hot showers! The charge is usually \$1.50 to \$2.00 per day.

I don't like to pull a trailer, because at times we may travel several hundred miles to visit a lake. We carry everything on top and in a station wagon. The boat on the roof is right side up, and carries the light camping equipment, such as gas cans, boat cushions, etc. The heavy items, such as motors, etc. are carried inside the wagon.

At the camp site we sleep in a thermos pop tent which goes up in two minutes, and can be set up on a flat rock, no ropes or pegs. However, I do peg it down if it is windy. While camping we have found through trial and error and much changing of equipment, that your camp must go up quickly, or camping becomes a chore and no longer fun. We use air mattresses and sleeping bags, if it is cold. All sites have tables; - you need a stove, pots and pans from your kitchen - and you are now ready.

I like to carry two identical motors, and in this way I am never stuck for parts, - at least not up to this writing. I have both small and large motors; but when we travel I use only the 4 cylinder 25 H. P. because we need the extra push for water skiing.

The KG - 9 and MK - 40 Mercurys are the first 4 cylinder motors in the Mercury line. They are in fact Mercury antiques, even though they were post-war (49 to 53). There is very little difference between the two; the largest difference is that the MK - 40 has a recoil start and the KG - 9 has a rope start. I shall have details and performance data when my KG - 9 is finished and run; this will be in a later letter. Presently I am working on 2 KG - 9s and 2 MK - 40s and one Super-ten. I never run in salt water, so my engines remain in excellent condition.

The boat I have now has been restored, and I shall refinish it again for the coming summer. It is a 13-1/2 foot Sid craft, a racing utility and weighs 180 pounds which makes it easy to load and unload. It will carry four people. Also, it pulls a skier nicely. It is quite safe on the turns and in rough water. It is not the softest riding boat around, but not the hardest either. For our use it is just about perfect.

Here is a thought for the antique outboard collector who would like to run his motors but has no boat: Most camping areas on the water rent boats!!! You can carry your motor in the trunk of your car along with a tent, a stove, and a can of beans and have a great time. If you are lucky, you may even catch a fish to go with the beans. Enough jokes - I always carry fishing equipment, but never get to use it because we are always so busy with the boat and motors.

I am always glad to hear about a good camping and boating area. If you know of one please drop me a line. I would also like to hear from anyone who has or is restoring a KG - 9, MK - 40 or Super-ten. By this time you might think that I'm interested only in Mercurys. NOT SO. I have hopes of also owning a 4-60 Evinrude and a PR-65 Johnson on which I have a line. I may get lucky!

See you all at the next meet. Keep your plugs dry!

Yours truly,

Stanley DuBois
430 East 72nd Street
New York City, New York
10021



Stan's Magic Carpet to
antique motor adventure

AOMCI

SPECIAL

Feature

JOHNSON BIG TWIN

SIX HORSE POWER

Model P-30

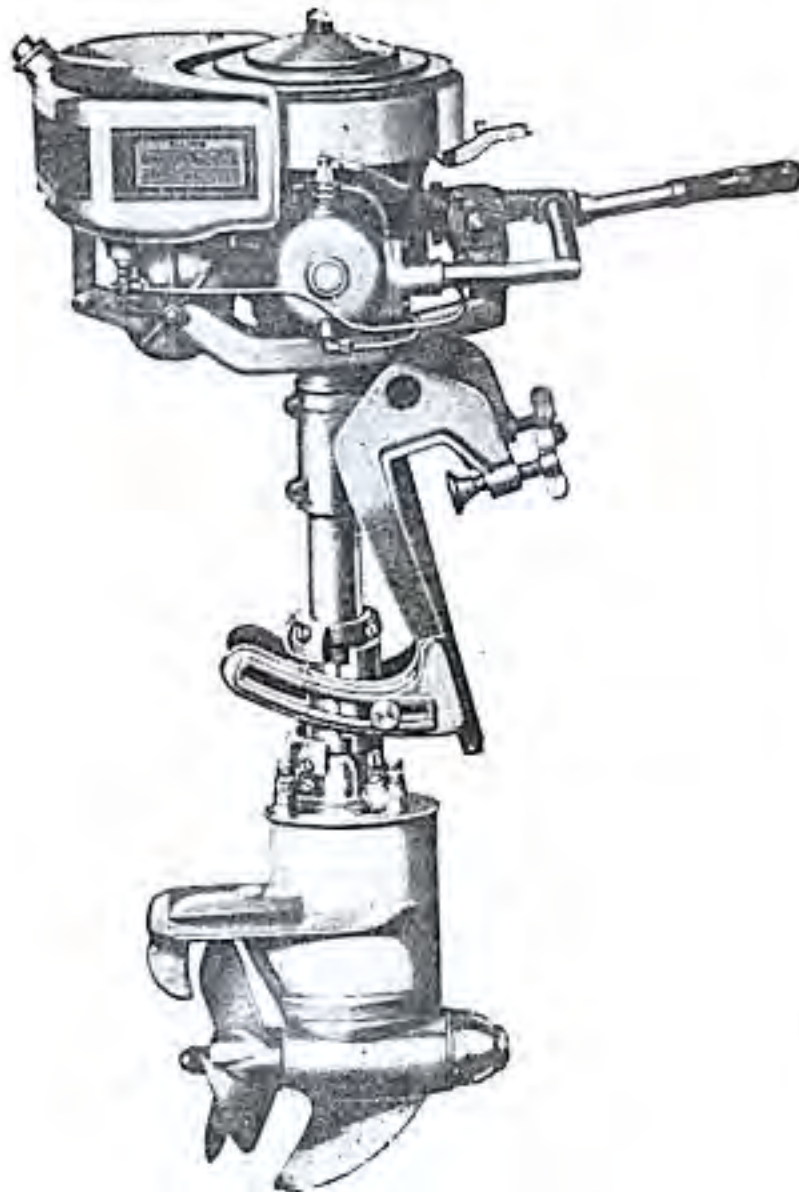

JOHNSON MOTOR COMPANY

WAUKEGAN, ILL.

BY J.L. SMITH

From the Model A Light Twin which had proved highly popular during the preceding four years, the Johnson Motor Company evolved the Big Twin, Model P-30. According to Bowman's Encyclopedia the Big Twin made its first competitive appearance on July 4, 1925, and took the racing lead at White Lake, Michigan. Here, it easily dominated the events and set a peak speed record of 16.68 mph, but by the end of the season this mark had been improved to 23.32 mph.

From 1922 competition between Evinrude and Johnson had been very lively. Each presented very colorful claims to the extent that these two companies accounted for the bulk of advertising in the area of outboarding. The P-30 was a natural outcome of this competition and the motor was immediately used in racing to demonstrate superiority over others.

However a close inspection of the Big Twin would indicate that it is more nearly suited for work horse capabilities. The construction throughout is rugged and heavy. The massive flywheel is ten inches in diameter. Inside is the single coil, condenser and point assembly mounted on the stator plate which can be rotated to advance and retard. A pulley plate on the flywheel provides for rope or "armstrong" starting, usual at that time. For spark plugs the old adage "when in doubt try C-7's" would be in order for these are the ones recommended.

Apart from the general appearance of the powerhead, the P-30 departs radically from the Model A Light Twin particularly in the muffler, driveshaft housing and lower unit. Exhaust manifold castings are of aluminum alloy and finned for better cooling. The P-30 was designed with an above water exhaust system. Beginning with the Model P-40 and sometimes retrofitted to the P-30, the Johnson company furnished a round sheet iron muffler which has a squarish extension projecting backwards from it. A cast aluminum exhaust pipe is bolted to this and extends downward into the water in an effort to provide quieter operation. About halfway down its length a valve is built into the pipe which can be adjusted to allow for above water release of the exhaust. At its base, the pipe is supported by a steel strap bolted to the lower unit.

The driveshaft housing is large and of cast aluminum alloy but the lower unit itself is a source of wonderment in its massive proportions. Again of cast aluminum, it is roughly the size of the units used in much later 25 HP engines. No water pump is used. Employing a pressure vacuum system, water for cooling is forced into a scoop by propeller thrust and forward movement of the motor and drawn out a rearward facing exit by exactly opposite forces. All in all the motor gives the appearance of a heavy duty machine. The final surprise comes when we see the weight at 80 lbs. and the horsepower specified at only six at 2500rpm. The instruction manual recommends 3/4 pint Mobiloil 'A' per gallon for oiling in ordinary service

and 1-1/2 pints Mobiloil 'A' oiling for high speed service in racing trim. The welded sheet aluminum gas tank has a capacity of 2-1/2 gallons. A variety of 2 and 3 blade lynite or bronze propellers were available depending on conditions of use.



The large cast iron opposed cylinders have a bore of two and seven-eighth inches and with a stroke of one and three-quarter inches there is a total of 22.7 cubic inches piston displacement. Inside there are strong bronze connecting rods and sturdy case hardened crankshaft with large bushings for the journal bearings. Needle and roller bearings were not as yet in common use.

Mounted on the split type crankcase and facing forward is the Johnson made float feed carburetor, a larger edition of that found on the Light Twin and carburetion is likewise accomplished using the port system. The familiar rectangular shaped carrying rail made of brass tubing and bolted to the cylinders also serves as support for the steering handle.



With a price tag of \$210.00 the P-30 Big Twin was continued through 1926. The following year in 1927 the Big Twin designated P-35 was available but with some changes including an increase of about five cubic inches in piston displacement. However the P-30, the first of the larger opposed twins set the pattern and demand for more powerful engines. Competition racing provided the impetus for improvement and the P-30 was undoubtedly the forerunner of a series of large opposed twins culminating in the highly successful PR-65. From it also developed a host of larger utility twins including the Model PO produced as late as 1950. Of relatively short production, probably few samples of this remarkable engine survive today, but we must salute the P-30 Big Twin as a true pioneer in the outboard motor industry.

*A New and
Convenient
Container for
Extra Gas*



*Makes It
Possible to Fill
Tank With
Utmost Ease*

The Elto Spare Gas Can

This new and convenient container, for extra gas, is equipped with a flexible pouring tube and special nozzle to fit opening in the Elto Gas Tank.

It is compact, requiring a space of only a trifle more than 9 inches high. The flexible pouring tube slips inside of can when not in use.

Holds Two Gallons

The Spare Gas Can holds two gallons, which, added to the capacity of the motor tank, provides a very convenient cruising radius.

It is made of heavy galvanized steel, painted a bright red. Leak proof. Made to last. No ordinary knocking about will mar or dent it. The flexible tube makes it possible to fill the Elto tank without the slightest inconvenience. No funnel needed. Every drop goes directly into the tank.

With an Elto Spare Gas Can under the seat, Elto owners need never run out of gas.



\$3.50 EACH
F. O. B. MILWAUKEE

Gem Grease Gun - \$2.00

This gun has been on the market for some years. The barrel is made of heavy steel in an excellent gun metal finish. The Gem Gun is easily operated and rapidly converted from grease to oil and back again.

This gun has proven by many years of use that it is practically indispensable. Heavy grease can be packed into either end and the screw plunger allows the gear housing to be packed tightly with grease.

The barrel is 1 3/4 in. in diameter, 7 in. long. The gun has a capacity of 8 ounces of grease or oil.



Kapo Life Saving Water Vest

The Kapo Life Saving Vest is an absolute guarantee of safety when racing, boating, fishing or hunting. Cut with generous arm holes, won't bind. Tie strings make it easily adjustable. Let out or take up to suit the wearer. Strong, not easily ripped, O. D. cloth contains enough Kapo Ceibasilk to float any person for hours.

Size 2—32 to 36 Chest \$6.50
Size 3—38 to 44 Chest 7.00

Kapo Life Preserver Pillow

Artificial Leather Pillows are filled with 1 pound Kapo Ceibasilk which is 4 times more buoyant than cork. Size 16x16 in. These pillows will pass Government inspection taking the place of cork filled life preservers on pleasure boats. In addition to affording a measure of safety they also are a great comfort especially when boating, racing, fishing, hunting, etc.

Price \$2.00



Three Great Motors



Super Elto
QUAD



Super Elto
SPEEDSTER



Super Elto
SERVICE TWIN

The
Super Elto
Starts with a quarter turn.

Four Accessories
Every Outboard Owner
Should Have



ELTO OUTBOARD MOTOR COMPANY

OLE EVINRUDE, *President*

62 MASON STREET MILWAUKEE, WIS.



You may have noticed in the Trader's Cove of the October 1968 issue, that in addition to printing the model and serial numbers of the Johnson and Neptune motors in the motors for sale section, the year of manufacture and horsepower of the individual motors was printed. This information is obtained by researching each motor for in 99% of the cases the owner was not aware of the year of his motor or how much horsepower it had.

This month, the list of motors researched included not only Johnson and Neptune, but also Elto, Evinrude, and Sea King. Model names are given where applicable. What's the reason for all this. The answer is the first sentence I ever wrote in the Antique Outboarder way back in October of '66, "In order to make this section, the Classified Section of the Antique Outboarder, a much more enjoyable and infinitely more informative Section." The last thing in the world that I want, is for Trader's Cove to come out like a telephone book.

GENERAL REQUIREMENTS APPLICABLE TO CLASSIFIED ADVERTISING

1. a) Members- Complete AOMC Form 101 or include: Make, Year, Model, Serial, number of cyl, runs or not, condition of compression and spark, list parts missing, give overall condition, features, price, state if member.
 b) Non-members must complete AOMC Form 101. Obtain forms from writer.
 2. Advertising rates: Members- Free; Non-members- \$1.00 per motor.
 3. Closing dates: All ads must be received not later than the 1st of the month preceding the date of issue.
 4. Transactions based on good faith: Deliberate misrepresentation, or violation of the code of business ethics and good sportsmanship, will constitute grounds for refusal of advertising, and may result in disbarment from this club.
 5. Warning to purchasers: The AOMC will accept no responsibility for any unsatisfactory transaction involving articles which either have or have not been described in accordance with the provisions of paragraph one.
-

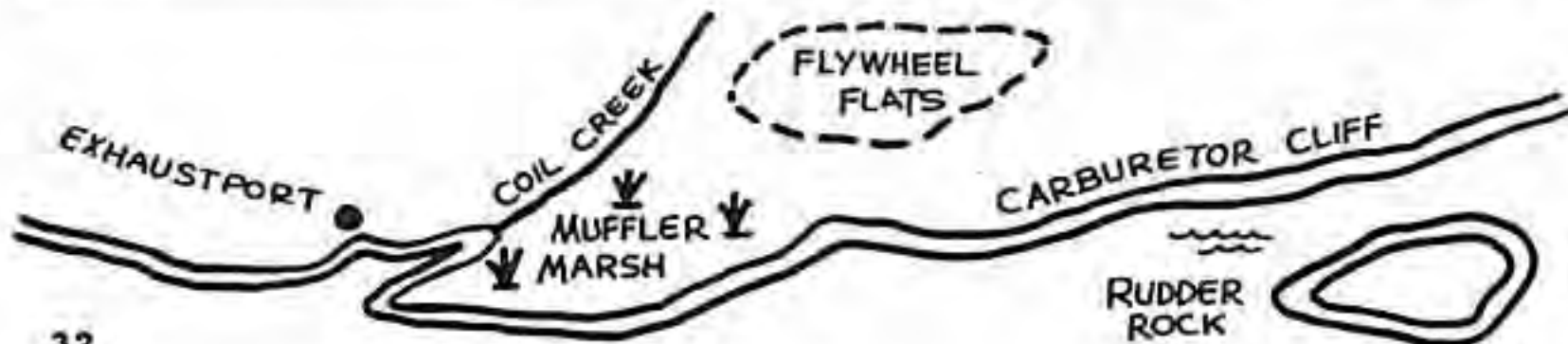

MOTORS FOR SALE

- BENDIX- Mod SMD, Ser D3634, single cyl, runs, complete, good comp & spark, Paul Labprise, 3002 Mayfair Victoria, Texas
- BENDIX- MOD SMD, Ser 5C2247, single cyl, runs, complete, broken prop, Lynn Anderson, Box 491, Lewisville, Idaho
- CAILLE- Liberty Single, runs, complete gas tank slightly dented, good over all cond, Bruno Pisaneschi, 7306 Lakeview, Ava RD #1, New York
- CAILLE- Mod 7, Ser 7, large opposed twin, does not run, good comp, fair cond, Lawrence Howard, 6539 Dodson Road, Wyoming, New York
- CAILLE- Mod 15, Ser 18005, Red Head, good comp, complete, variable pitch prop, Lionel Schensol, 121 East St. Wrentham, Massachusetts
- CHAMPION- Mod SIG, Ser 38370, 1941 ? single cyl, complete, starts on first pull, N.M. Dietrich, 1569 Sunnyvale Walnut Creek, California
- CLARKE- Troller, Ser TP391740, single cyl, does not run, good comp, no spark Frank Power, 2520 East Dorothy Lane, Kettering, Ohio
- ELTO- Ser 3905, 1922, 3.0 HP, opposed twin, has rudder, runs, complete, Joseph Mallett, 199 Hope Avenue, Worcester, Massachusetts
- ELTO- Lightweight, 1929, (should be Ser 309-), casting that holds name-plate damaged, complete, David Evert, Route 2, Union City, Michigan
- ELTO- Mod C, Ser 22959, 1925, 3.0 HP, opposed twin, has rudder, battery ign, runs, complete, Alvin Brown, 239 Mt. Ida Ave., Lancaster, Ohio
- ELTO- Mod H, Ser 34728, 1926, 4.0 HP, opposed twin, fair overall cond, runs, complete, Frederick Johnson, 1749 Mentor Ave., #28, Painesville, Ohio
- ELTO- Mod J, Ser 54106, 1927, 4.0 HP, opposed twin, has rudder, battery ign, complete, last ran in '54, James Conway 720 Jacobson, Madison, Wisconsin
- ELTO- Speedster, Mod 355, Ser 63455, 1928, 7.0 HP, opposed twin, battery ign good cond, Alvin Brown, 239 Mt. Ida Ave., Lancaster, Ohio
- ELTO- Senior speedster, Mod 311, Ser 0451, 1930, 14.0 HP, opposed twin, runs, complete, August Sues, 145 Pippin Way, Santa Cruz, California
- ELTO- PAL, Mod 4253, Ser 05355, 1938, 1.1 HP, single cyl, runs, complete, gas tank leaks, Marvin Schmitz, 1409 7th, Peru, Illinois
- ELTO- Ace, Mod 4351, Ser 06099, runs, shut off valve on gas tank missing, rust in gas tank, Edward Ashland, 1031 Jane N.E. Albuquerque, New Mexico
- EVINRUDE- Mod ? Ser ? (Row Boat Motor from description), gas tank bracket missing, runs, Robert Tucker, Box 401, Paoli, Pennsylvania
- EVINRUDE- Mod 7 Ser 7 Row Boat Motor, complete, keyway on crankshaft damaged, runs, Richard Fischer, 528 Larschied St. Green Bay, Wisconsin
- EVINRUDE- Row Boat Motor, Ser 6235, 1920, 3.5 HP, single cyl, complete, does not run, needs coil, Cecil Hartwell, RR#1, North Vernon, Indiana
- EVINRUDE- Row Boat Motor, Mod A, Ser 107892, 1920, 2 HP, single cyl, one motor clamp missing, Ray Westfall, 5353 N. 58th, Milwaukee, Wisconsin
- EVINRUDE- Big Twin, Mod LAT, Ser 1572 opposed twin, running cond, complete, has twist reverse, Robert Purdy, 2320 Hickory, Portage, Indiana
- EVINRUDE- Fleetwin, Mod F, Ser 2F-499, 1929, 7.0 HP, opposed twin, good comp, gas tank dented, Bernard Helmos, 1556 Algonquin, Des Plaines, Illinois
- EVINRUDE- Speeditwin, Mod U, Ser 1U303 opposed twin, 1929, 20 HP, runs then stalls, spark & comp good, Donald Peterson, 1050 NW 5th, Salem, Oregon
- EVINRUDE- Speeditwin Electric, Mod 636 Ser 0007, opposed twin, runs, complete ameter does not work, Richard Warnock 1886 Ridge Road, Union Hill, New York
- EVINRUDE- Handitwin, Mod 4218, Ser 01176, opposed twin, runs, complete, good cond, Robert Beideck, 34 Hubbard North Chili, New York
- EVINRUDE- Fisherman, Mod 4227, Ser 00903, 1937, 4.4 HP, opposed twin, runs, complete, William Morris 807 Springwood Drive, Orlando, Florida
- EVINRUDE- Mate, Mod 4263, Ser 00572, 1939-41, 0.5 HP, single cyl, runs, complete, Vernon Lewis, Glenwood Road, Riverside, Washington
- ELTO- Speedster, Mod 355, Ser 65620, 1928, 7.0 HP, runs, complete, battery ign, Edward Kowaloyk, 3714 Pearl St., Batavia, New York
- ELTO- Senior Quad, Mod 732, Ser 2, 1933 31.2 HP, needs handle brackets & plug covers, lower unit marginal, Bill Kelly 10201 114th Pl. NE, Kirkland, Wash.
- EVINRUDE- Sport Single, Mod 432, Ser 0302, 1933, 2.2 HP, single cyl, complete runs, Edward Kowaloyk, 3714 Pearl St. Batavia, New York

MOTORS FOR SALE

- EVINRUDE- Ranger, Mod 4265, Ser 03349, 1939, 1.1 HP, single cyl, can run, rope starter pulley missing, R. Brandes, 40 Home, Gillette, N.J.
- EVINRUDE- Sportwin, Mod 4305, Ser 02908, 1939, 3.3 HP, Twin cyl, tiller & carb bowl missing, tank leaks, C. Myers, 4416 NE 40th, Portland, Oregon
- EVINRUDE- Handitwin, Mod 4307, Ser 02452, 1939, 3.0 HP, runs, twin cyl, Harry Bradley, 520 Ann Street Lake Charles, Louisiana
- EVINRUDE- Lightwin, Mod 4313, Ser 00544, 1939, 5.0 HP, runs, carrying handle missing, Ed Hajder, 5600 35th Ave. North, Minneapolis, Minn.
- EVINRUDE- Speeditwin, Mod 6039, Ser 09172, 1941, 22.5 HP, runs, complete, Fair cond, Claude Wells, Box 181, Rawlins, Wyoming
- EVINRUDE- Zephyr, Mod 4378, Ser 02253, 4 cyl, runs, complete, gears in lower unit need replacement, Quentin Pech 1145 N 17th, Manitowoc, Wisconsin
- EVINRUDE- Lightfour, Mod 4383, Ser 04695, 1946, 9.7 HP, runs, complete, K.D. Buckingham Jr., 424 Fond du Lac Ave., Sheboygan Falls, Wisconsin
- EVINRUDE- Zephyr, Mod 4404, Ser 72381, 1948, 5.4 HP, 4 cyl, runs, rewind starter worn, rope started, C. Saunders 1236 Balmoral, Pittsburgh, Pennsylvania
- EVINRUDE- Ranger, Mod 4407, Ser 09557, 1946-47, 1.1 HP, single cyl, runs, complete, skeg broken, David Hicks, 1015 Jefferson, Traverse City, Mich.
- EVINRUDE- Speeditwin, Mod 6039, Ser 51080, 1950, 22.5 HP, opposed twin, runs, complete, C. MacFarlane, RR #1 St. Andrews, New Brunswick, Canada
- LAUSON- Ser 70B2281, year ?, HP ?, cyl ?, 4 cycle, air cooled, runs, Edward Kowaloyk, 3714 Pearl Street, Batavia, New York
- LAUSON- Mod S350, Ser 13754, single cyl, 4 cycle, air cooled, runs, complete, Gordon Oberg, 2810 Bemidji Ave., Bemidji, Minnesota
- LOCKWOOD-ASH- Row Boat Motor, Mod A, Ser 258, Has an Evinrude tank, has rudder & knuckle bustar. J. Noonan, 7454 W. Thurston, Milwaukee, Wis.
- MARTIN- "100", Perfect cond, original Black & Hammertone finish, runs, complete, Bill Kelly, 10201 114th Pl. NE, Kirkland, Washington
- NEPTUNE- Mod OB-15, 1931, 16.0 HP, Readily restored, Eisman Magneto MS47A carb, Bill Kelly, 10201 114th Pl. NE, Kirkland, Washington
- JOHNSON- Mod A, Ser 2220, 1922, 2 HP, opposed twin, runs, complete, neat & clean looking, Russell Larson, 2519 Green Street, Racine, Wisconsin
- JOHNSON- Mod A, Ser 16459, 1923-24, 2 HP, opposed twin, runs, complete, T.M. Bliss, 4616 Crestview Road, Sylvania Ohio
- JOHNSON- Mod A-25, Ser 24228, 1925-26 2 HP, opposed twin, complete, rust in cylinders, John Winslow, 1141 North 78th, Seattle, Washington
- JOHNSON- Mod A-25, Ser 39235, 1925-26 2 HP, opposed twin, runs, complete, William Hermameier, 1449 Holkinwood Drive, Freeport, Illinois
- JOHNSON- Mod A-25, Ser 40243, 1925-26 opposed twin, will run, complete, Chet Hook, 202 North Martin, Waukegan, Illinois
- JOHNSON- Mod A-35, Ser 48990, 1927-28 2.5 HP, opposed twin, Leonard Weismiller, 8991 Quandt, Allen Park, Michigan
- JOHNSON- Mod A-35, Ser 76543, 1927-28 2.5 HP, opposed twin, runs, complete, Stanton St. Peter, 2654 Edison Street San Mateo, California
- JOHNSON- Mod A-35, Ser 7, 1927-28, 2.5 HP, opposed twin, runs, complete, John Zanotti, 2660 Maywood Drive, San Bruno, Cal.
- JOHNSON- Mod K-35, Ser 67946, 1927, 6.0 HP, opposed twin, runs, complete, motor leg has weld, Jack Hariu, Route 3, Mc Grager, Minnesota
- JOHNSON- Mod K-40, Ser 80677, 1928, 7.15 HP, opposed twin, runs, steering handle missing, John Bierma, 74 Glen Cameron, Thornhill, Ontario, Canada
- JOHNSON- Mod ?, Ser ?, (no model # but he says its a Giant Twin) (I'd ask for a photo with him next to it), runs, Compl, J. Polivka, 2734 Veteran, Los Angeles, Cal
- JOHNSON- Mod A-45, Ser 123663, 1929, 3.0 HP, opposed twin, runs, complete, Andrew Salitros, 8700 Portland Ave. Bloomington, Minnesota
- JOHNSON- Mod A-45, Ser 124567, 1929, 3 HP, opposed twin, tank dented, prop chipped, runs, Darrell Anderson, 3011 Twin City Drive, Council Bluffs, Iowa
- JOHNSON- Mod K-45, Ser 104706, 1929, 7.15 HP, opposed twin, runs, complete, gas tank dented, M. Weatherbee, 219 Crowley, Buffalo, New York
- JOHNSON- Mod S-45, Ser 124865, 1929-32 13.0 HP, opposed twin, runs, complete, Donald Warner, 104 Wheeler Ave. Toronto, Ontario, Canada

MOTORS FOR SALE

- WILLS- Liberty twin, opposed, runs, complete, clean, good overall cond, Walter Kushion, 120 South Main St., St. Charles, Michigan
- WILLS- Liberty twin, opposed, runs, tank slightly dented, good overall cond, H.M. Randall, Box 5095, Yucca, Arizona
- WILLE- Mod 109, single cyl, variable pitch prop, runs, complete, Harry Bialik, 1576 Beardsley St. Muskegon, Michigan 49441
- ELTO- Mod G, Ser 30466, opposed twin flywheel, ignition & carb missing, Edward Baron, R.D. 1 Box 122, New Salem, Pennsylvania
- ELTO- Mod J, Ser 53350, opposed twin, runs, complete, 1927, 4 HP, Thomas Simek, 332 North 62nd St., Wauwatosa, Wisconsin 53212
- ELTO- Speedster, 1929 ?, opposed twin, runs, skag broken, steering handle missing, Floyd Studebaker, 1810 Champlain, Ottawa, Illinois
- ELTO- Mod 355, Ser 65212, Speedster, 1928, 7 HP, opposed twin, runs, complete, Floyd Cook, 410 Hamilton Washington, Illinois 61571
- EVINRUDE- Row Boat Motor, Mod A, Ser 7, single cyl, complete, has reverse, Stanley Cobbett, 800 Washington, East Bridgewater, Mass.
- EVINRUDE- Row Boat Motor, Mod A, Ser 52700, single cyl, does not run, complete, Marty Silvi, Box 6015, West St. Paul, Minnesota
- EVINRUDE- Row Boat Motor, single cyl, has cracked water jacket, runs, complete, E.D. Hughes, Rt 2 Box 13, Philomath, Oregon 97370
- EVINRUDE- Row Boat Motor, single cyl, Mod B, Ser 17336, runs, complete, good cond, Olin Salmon, 4 South Central Ave, Mechanicville, N.Y.
- EVINRUDE- Row Boat Motor, Single cyl, Mod A, Ser 116311, 2 HP, 1921, Mr. H. Mueller, 305 East 26th, Kearney, Nebraska 68847
- EVINRUDE- Sportwin, Mod N, Ser 15072, opposed twin, runs, "a fine looking motor from photo- RZ", Rev. Butts, Box 208, Stockton, Missouri (2.5 HP, 1928)
- EVINRUDE- Fastwin, Mod-Ser 12H034, 14 HP, 1929, opposed twin, complete, does not run, Michael Lindgren, 602 Liberty Uniondale, New York 11553
- EVINRUDE- Sportwin, Mod 409, Ser 3572, 4 HP, 1932, opposed twin, complete, runs, Frank Ceustard, Box 152, Trumbull, Connecticut 06611
- EVINRUDE- Sportsman, Mod 4091, Ser 1974, 1.5 HP, 1935, single cyl, runs, complete, A.E. Lill, 55 Woodlawn, St. Charles, Missouri
- EVINRUDE- Speeditwin- Electric Start, 21.1 HP, 1935?, Mod ?, Ser?, opposed twin, frozen motor, C. Ebbinghaus, R.R. 2, Albany, Indiana
- EVINRUDE- Speeditwin, Mod 6015, Ser 0038, 21.1 HP, 1935, runs, complete, John Kunz, 5030 South 68th, Greenfield, Wisconsin
- EVINRUDE- Sportsman, Mod 4146, Ser 04639, 1.5 HP, 1936, single cyl, runs complete, Richard Schleder, 153 Bernice Stockton, California
- EVINRUDE- Speedifour, Mod 7026, Ser 00179, 33.4 HP, 1938, 4 cyl, almost new cond, runs, complete, G. Neuens, 3307 N. 76th, Milwaukee, Wisconsin
- EVINRUDE- Ranger, Mod 4265, Ser 02479, 1.1 HP, 1939, single, runs, complete, Gustave Ozag Sr., 4251 West Irving Park Road, Chicago, Illinois
- JOHNSON- Mod J-25, Ser 37742, single cyl, runs, complete, very good cond, Hartland Smith, Box 452, Birmingham, Michigan
- JOHNSON- Mod A-25, Ser 20701, opposed twin, 2 HP, 1925, does not run, complete Byron Elsbough, Box 414, Tyler Ave., Miller Place, New Jersey 11764
- JOHNSON- Mod A-25, Ser 39961, opposed twin, 2 HP, 1925, runs, complete, Louis Baldyga, 82 Palmer Street, Three Rivers, Massachusetts
- JOHNSON- Mod A-35, Ser 73810, opposed twin, 2 HP, motor frozen, exhaust manifolds & muffler missing, G. Richter, 3657 Burbridge, Cleveland Hts. Ohio
- JOHNSON- Mod K-35, Ser 38874, opposed twin, 6 HP, 1927, runs, complete, Kenneth Kowalk, 624 Kent Street, Wausau, Wisconsin 54455
- JOHNSON- Mod K-35, Ser 53795, opposed twin, 6 HP, 1927, needs muffler, runs, G. Neuens, 3307 North 76th Street, Milwaukee, Wisconsin 53222
- JOHNSON- Mod P-35, Ser 49756, Big Twin, 8 HP, opposed twin, complete, runs, Norman Krause, Rt 1, Box 418, Rainier, Oregon 97048
- JOHNSON- Mod P-40, Ser 72853, Big Twin, 13.15 HP, 1928, does not run, Has cracked water jackets, complete, Norman Coope Box 664, Avalon, California 90704
- JOHNSON- Mod V-45, Ser 116637, 4 cyl, 26 HP, 1929, runs, complete, fair cond, Clarence Minor, 40 Turnpike Road, Townsend, Massachusetts 01469

MOTORS SEEN

MOTORS FOR SALE

JOHNSON- Mod J-25, Ser 131839, 1932
1.5 HP, single cyl, runs, complete,
almost new cond, G. Castle, 20085
Redwood, Castro Valley, California

JOHNSON- Mod PR-?, Ser ?, has exhaust
stacks, vacturi carb, raced until 2
yrs ago, runs, Ronald Rowland, Box 77
Bloomington, Ohio

JOHNSON- Mod F-75, Ser 223671, 1935,
3.3 HP, opposed twin, does not run
complete, Jack Wyant, 4869 Mayfair
North Canton, Ohio

JOHNSON- Mod ?, Ser 550374, large
alt twin, (looks like K series) runs,
rewind starter drags, C.L. Ragland,
5819 Horton, Mission, Kansas

JOHNSON- Mod 100, Ser 235362, 1936
1.7 HP, single cyl, runs, complete,
Good cond, W.K. Rhineamith, 10031
Old Orchard Road, La Porte, Texas

JOHNSON- Mod 200, Ser 237799, 1936
3.3 HP, opposed twin, runs, complete
gas tank has weak spot, C.A. Moore,
1436 North 52nd Street, Ft. Smith, Ark.

JOHNSON- Mod 200, Ser 237808, 1936,
3.3 HP, opposed twin, runs, complete,
needs new muffler, James Bell, 34
Gulliver Road, Toronto, Ontario, Can.

JOHNSON- Mod P-80, Ser 250172, 1936
22.0 HP, opposed twin, runs, complete
good cond, \$25, Robert Purdy, 2320
Hickory, Portage, Indiana

JOHNSON- Mod PO-37, Ser 283280, 1937
22.0 HP, opposed twin, runs, complete
has racing stacks, Richard Washinsky
Rt. 1, Cass Lake, Minnesota 150.00

JOHNSON- Mod LT-38, Ser ?, 1938, 4.2
HP, alternate twin, runs, complete,
slight dent in tank, Edward Kowalozk
3714 Pearl, Batavia, New York

JOHNSON- Mod MS-39, Ser 316521, 1939,
1.1 HP, single cyl, runs, complete,
tank dented, Richard Warnock, 1886
Ridge Road, Union Hill, New York

JOHNSON- Mod PO-39, Ser 309194, 1939
22.0 HP, opposed twin, runs, complete
Has two of these motors, Chet Hook,
202 N Martin, Waukegan, Illinois

PARTS WANTED

JOHNSON- Mod A-45, needs starboard
cylinder, Marcus Wright, 30 Crest
Drive, Little Silver, New Jersey

JOHNSON- Mod PO-15, Ser 484031, 1945,
22.0 HP, opposed twin, runs, complete,
good cond, Frank Cotrones, 3462 South
Lundy, Tucson, Arizona

JOHNSON- Mod PO-15, Ser 784349, 22 HP,
1941-50, opposed twin, runs, steering
handle missing, L.A. Wilson, Box 764
Big Piney, Wyoming

JOHNSON- Mod POLR-15, Ser ?, 22.0 HP
1941-50, opposed twin, runs complete,
John Watson Sr. 329 South Cherry St.
Richmond, Virginia

LOCKWOOD- Mod NA, Ser 1588, 1914 ?,
single cyl row boat motor, has rudder,
battery ign, runs, complete, W. Garland
Box 514, Coeur d'Alene, Idaho

MOTORGO- Mod ?, Ser ?, very old single
forwardpointing cyl, cast gas tank, brass
lower unit, complete, Nick Nocchi, 7507
Walford, Niles, Illinois

NORTHWESTERN- veryold forward pointing
single, water pump & exhaust manifold
missing, prop shaft & flywheel poor, H.C.
Williams, 9709 Sixth, Inglewood, Calif.

NEPTUNE- Mod OB-16, Ser 9396, 1932, 16
HP, opposed twin, runs, complete, good
condition, Robert Purdy, 2520 Hickory,
Portage, Indiana

SEA KING- Mod 415, Ser 0313, opposed
twin, folding lower unit, runs, complete
1932-34, 3.0 HP, Charles Hayen, 2804
Ohio Ave, Baltimore, Maryland

WISCONSIN- very old forward pointing
single, has knuckle buster, fair cond,
arnest Pape, 1402 Fairview, Caldwell,
Idaho.

ALTO- Mod C, Ser 12542, 1924, 3.0 HP,
opposed twin, complete, has rudder,
fair cond, Thomas Garavacha, 13399
Evanston, Detroit, Michigan

EVINRUDE- Row Boat Motor, Mod B, Patent#
16237, single cyl, runs, complete, 1915-
24, Mara Howell, 2673 Chestnut St,
Eric, Pennsylvania

EVINRUDE sportwin, Mod 409, Ser ?, 1932
4.0 HP, opposed twin, runs, complete,
good cond, J.L. Puttock, 7384 Lake St.
Pulaski, New York

PARTS WANTED

KOBAN- needs later style gas tank,
exhaust manifold, muffler, William Jones
Ely Lake, Eveleth, Minnesota

JOHNSON- Mod A, needs cast aluminum gas
tank, will buy parts motor to get tank,
Larry Ward, 2460 Riverside Drive,
Beloit, Wisconsin

MOTORS FOR SALE

ELTO- Lightwin, has runner, Mod 7, Ser 7, ran 5 years ago, complete, good cond, Larry Carriveau, 12502 West Honey Lane, New Berlin, Wisconsin

JOHNSON- Mod A-50, Ser 132678, 4 HP, 1930, alternate twin, complete, runs, John Mattern, 8304 Grand Avenue, Omaha, Nebraska

JOHNSON- Mod PE-50, 20 HP, 1930, opposed twin, runs, complete, good cond, Al Meinke, 15110 Hook Hollow Rd. Novelty, Ohio

JOHNSON- Mod J-25, Ser 160649, 1932, single cyl, motor is brand new & never on boat, L. Stevenson, 4715 Dunberry Lane, Minneapolis, Minnesota

JOHNSON- Mod J-65, Ser 206116, 1935, single cyl, 1.4 HP, complete, runs, tank dented, Al Kulupka, 100 Prairie St, Spring Valley, Illinois

JOHNSON- Mod 7, Ser 7, single cyl, model from late thirties, runs, complete Tom Dickey, 1016 Dean Drive Northwest, Atlanta, Georgia 30318

JOHNSON- Mod 210, Ser 267837, 5.3 HP, 1937, twin cylinder, runs on only one cylinder, Max Hoffmann, 304 East Second, Trenton, Illinois 62293

JOHNSON- Mod LT-38, Ser 289008, 1938, 4.2 HP, alternate twin, runs, complete C. Hulmes, 2112 Northeast 63rd Street Vancouver, Washington

JOHNSON- 2 motors Mod HS-10 & HS-15, 2.5 HP, alternate twin, 1 runs & 1 is parts motor, Elmer Hohn, 709 Shadyside, West Mifflin, Penn. 15122

JOHNSON- Mod LT-10, Ser 379705, 5 HP, 1940, alternate twin, complete, needs tuning, Ralph Birdwell, 9 Magnolia Petaluma, California 94952

LOCKWOOD- Mod 72T, Ser 6935, complete opposed twin, 7 HP, 1927, runs, John Zidow, 214 Lawndale Avenue Ottawa, Illinois 61350

NEPTUNE- Mod 320, Ser 2882M, 1932, opposed twin, runs good, complete, has new gas tank, C. Ebbinghaus, R.R.1, Albany, Indiana 47320

NEPTUNE- Mod 11B2, Ser 49319H2, runs, single cylinder, complete, hard starting, Merle Fuhrer, 606 North Miller, Santa Maria, California

THOR- Ser 12148, single cylinder, runs, complete, fair condition, Harry Tinklepaugh, 1219 North 19th St. Kansas City, Missouri 66102

PARTS FOR SALE

JOHNSON- Mod K-50, thru KD-15 many misc parts. Johnson- Mod A-50 thru A-80 many misc parts. Bill Salisbury, Member 1105 Hunterston Place, Cupertino, California 95014

LITERATURE FOR SALE

Miscellaneous old magazines for sale. Jerry Heermans, 16925 Southwest River Lane, Tigara, Oregon 97225

MOTORS WANTED

JOHNSON- Mod A-35. John Gould, Jr., 4707 Massachusetts Avenue, Indianapolis, Indiana 46218

PARTS WANTED- HELP fellow members!!!!

LOCKWOOD- Ace, Mod 92A, Ser 12299, needs magneto coil; ELTO- Super "C", Mod 605, Ser 0010, needs flywheel and complete ignition system. Paul Daykin, 331 Washington Street, Geneva, New York

LOCKWOOD- Ace, needs magneto plate assembly complete. Walter Weidmann, Route #2, Voorheesville, New York

JOHNSON- Mod A-35, needs carburetor parts. John Gould, Jr., 4707 Massachusetts Avenue, Indianapolis, Indiana 46218

PARTS WANTED

MERCURY- Mod KG9, needs test wheel for stock lower unit, 12.5 to 15 inch pitch Johnson prop for stock lower unit, one set of exhaust stacks, Stan Dubois, 430 East 72nd Street, New York, N.Y.

EVINRUDE- Ranger, Mod 4407, needs lower unit gear housing, SAM KING- Mod 379, needs coil, would buy whole magneto assembly for good coil. Philip Graen, 901 East Jefferson St. Bloomington, Illinois

ELGIN- Mod 571-85301, needs flywheel, Mark Schoeb, Cleveland, Minnesota

MOTORS WANTED

JOHNSON- Mod P-50 thru P-80, any one example. JOHNSON- Mod TR-40 or T-45 any condition, EVINRUDE- four cycle twin. EVINRUDE- pre 1935 Speeditwin Fastwin, ELTO- any model before 1935 over 5 HP, Any larger HP motor of an obsolete make such as Lockwood Chief Neptune Master Twin etc. MERCURY- Mod KG9 Thunderbolt with rope start, Bill Kelly, 10201 114th Place NE, Kirkland, Washington

PARTS FOR SALE

WATERWITCH- Mod MB, Ser 571-20, everything except rods. Philip Graen, 901 East Jefferson St. Bloomington, Illinois

JOHNSON- Mod Ka gearcase complete; Mod J rods & aluminum pistons; Mod A thru Mod 210 rings, standard bore; Models HS, HA, MS, MD rings, standard bore, .010 & .020 oversize. Plus many old parts too numerous to mention, write and ask by part number and description. LOCKWOOD- Acc, ignition coil. Bill Kelly, 10201 114th Place NE, Kirkland, Washington

MOTORS SEEN

ELTO- Mod H, 1926, D. Archibald, RR 1, Clearwater, B.C.

ELTO- Mod 4286 Pal, 1941, R. Baum, 610 Deerpark, Webster Grove, Missouri

ELTO- Mod 4284 Cub, 1939, C. Beney, 560 Montrose, St. Paul, Minnesota

MOTORS SEEN

CAILLE- Large opposed twin, variable pitch prop, Jack Albright, 5924 North Driscoll, Spokane, Washington

CAILLE- Large opposed twin, 22.5 HP 7, Floyd Ammon 200 South 43rd St. Louisville, Kentucky

CAILLE- Large opposed twin, variable pitch prop, Geoffrey Brose, 2369 Pine St., Napa, California

CAILLE- Mod 15, opposed twin, variable pitch prop, John Cook, Box 1509 El Centro, California

CAILLE- Liberty Drive, John Eckel, 2175 Orchard, Dubuque, Iowa

ROBERTS- 3 cylinder inboard, old, John Eckel, 2175 Orchard, Dubuque, Iowa

CAILLE- Mod 46, Class C, Vernon Freeze, 203 Shunway, Buffalo, New York

CAILLE- Mod 7, has Bosch Mag, Walter Kushion, 120 S Miami, St. Charles, Mich

CAILLE- Liberty Twin, William Papp, 315 Robinson, N. Tonawanda, New York

CAILLE- Large opposed twin, variable pitch prop, James Wareham, 322 South Duluth Apt 10, Sioux Falls, S. Dakota

CLARKE- Troller, William Burmeister 1537 York St, Lima, New York

CLARKE- Troller, Charles Calkins, 213 Main, Addison, Michigan

CLARKE- Troller, Harold Clemons, Millport, New York

CLARKE- Troller, L. Leahy, 337 Kelvie Avenue, Kirkland Lake, Ontario, Canada

CLARKE- Troller, Lynn Martin, 4248 Neptune, Salt Lake City, Utah

CLARKE- Troller, William Naus, 2030 Clinton, Toledo, Ohio

CLARKE- Troller, George Nygaard, 1277 Selma, Westland, Michigan

CLARKE- Troller, William Schultz, 1616 Brown, Saginaw, Michigan

ELTO- Mod 4253 Pal, William Schultz, 1616 Brown, Saginaw, Michigan

CLARKE- Troller, Robert Stanfield, 538 N. Lake, Harrison, Michigan

CLARKE- Troller, Robert Swyers, 208 S. Crawford, Troy, Ohio

CLARKE- Troller, Paul Welch, 5414 Knox, Shawnee Mission, Kansas

ELTO- Mod 4256 Ace, H. Alexander, 5201 Green Valley, Knoxville, Tenn.

ELTO- Mod J, 1927, Jackson Barnes, RD #1, Hook Stream, New York

ELTO- Mod J, 1927, Robert Beidle, Box 226, Cornucopia, Wisconsin

ELTO- Lightweight, 1929, A. Borchert, 701 Chapman, Mankato, Minnesota

MOTORS SEEN

ELTO- Mod G, 1926, H. Basman, 320
 Michigan NE, Grand Rapids, Mich.
 ELTO- Brass lower unit, R. Brosinger,
 2231 S 64th, West Allis, Wisconsin
 ELTO- Lightwin, 1927, C. Brownell,
 Hiway 41 W, Marquette, Michigan
 ELTO- Speedster, #65212, 1928, F. Cook
 410 Hamilton, Washington, Illinois
 ELTO- Lightwin, L. Andrews, 304 West
 Washington, Pasadena, California
 EVINRUDE- Row Boat Motor, L. Bartlett
 Swedeberg, Missouri
 EVINRUDE- Row Boat Motor, T. Bruce,
 1534 Union, Alameda, California
 EVINRUDE- Mod 4313, 1938 Lightwin, J.
 Bushaw, Warren, New Hampshire
 EVINRUDE- Mod A, Row Boat Motor, C.
 Caballero, 911 Main, Susanville, Calif.
 EVINRUDE- Mate ?, Alan Comeau, 56
 Stearns, Leominster, Mass
 EVINRUDE- Mod 4404, 2 motors, Zephyr,
 C. Coston, Rt 3, Ex 568, Hoquiam, Wash.
 EVINRUDE- Mate ?, W. Cox, 103 E Lynn,
 Seattle, Washington
 EVINRUDE- Mod 5039, 1946 Speeditwin, W.
 Curtis, 2801 Crockett, Ft. Worth, Texas
 JOHNSON- Mod KA-10, 1940, R. Barr, 95
 Main, Canton, New York
 JOHNSON- Mod HS-10, 1940, S. Simpson,
 2715 Center, Ingram, Pennsylvania
 JOHNSON- Mod A, D. McNall, 2B Angora,
 Scarborough, Ontario, Canada
 JOHNSON- Mod A-45, 1929, A. Allen,
 4127 S. Garfield, Spokane, Wash.
 JOHNSON- Mod A-25, 1925-26, R. Nelson
 Rt 2, Milaca, Minnesota
 JOHNSON- Mod P-40, 1928, N. Cooper,
 Box 664, Avalon, California
 JOHNSON- Mod J ?, W. Culver, 1525
 Morningside, Merritt Island, Florida
 JOHNSON- Mod OA-55, 1931, J. Knight,
 3086 Warrior, Hueytown, Alabama
 JOHNSON- Mod K-40, Mrs. F. Kettendorf,
 Star Rt 3, Fairbanks, Alaska
 JOHNSON- Mod A-35, 1927-28, R. Johnson
 Breedsville, Michigan
 JOHNSON- Mod J-25, H. Green, 1708
 S 12th, Lafayette, Indiana
 JOHNSON- Mod BV, S. Gerrish, West
 Peru, Maine
 JOHNSON*- Mod S-45, 1929-32, S. Gerrish
 West Peru, Maine
 JOHNSON- Mod P-50, 1926, W. Hoy, Box
 304, Central Valley, California
 JOHNSON- Mod V-45, 1929, C. Addison,
 Box 103, Winter Harbor, Maine
 JOHNSON- Mod 100, 1936, C. Hawkinson,
 319 NE 60th, Seattle, Washington
 ELTO- Pal, J. Bridenbaugh, 712
 Lafayette, Logansport, Indiana
 ELTO- LIGHTWIN, W. Brosman, Manhattan
 Park, Pennellville, New York
 ELTO- Mod 4203 Pal, L. Buitenhuys, 12
 Evergreen, Kington, Massachusetts
 ELTO- Super Lightwin, M.E. Creighton,
 Box 382, Gig Harbor, Washington
 EVINRUDE- Row Boat Motor, R. Barr, 95
 Main, Canton, New York
 EVINRUDE- Old Speeditwin, Don Bixer,
 7204 E 104th, Kansas City, Missouri
 EVINRUDE- Mod 432, 1933 Sport Single,
 F. Burke, 3114 N Newhill, Milwaukee, Wis
 EVINRUDE- Mod N, Sportwin, W. Butts,
 Box 206, Stockton, Missouri
 EVINRUDE- Mod 4322, 1941 Lightfour, E.
 Gazier, 200 N 3 East, St. Anthony Idaho
 EVINRUDE- Mate ?, G. Cooley, 1417
 Union, Schenectady, New York
 EVINRUDE- Mod 4092, 1935 Fisherman, K.
 Cote, RR 2, Kankakee, Illinois
 EVINRUDE- Row Boat Motor, G. Cullen,
 13527 115th, Edmonton, Alberta, Canada
 EVINRUDE- Row Boat Motor, D. David, 2010
 S.W. Blvd., Tulsa, Oklahoma
 JOHNSON- Mod A, S. Simpson, 2715 Center
 Ingram, Pennsylvania
 JOHNSON- Mod J-80, 1936, R. Higgins, 7074
 Brentwood, RR#1, Brentwood Bay, BC, Canada
 JOHNSON- Mod B, D. Brownell, 1280 Glines
 Santa Maria, California
 JOHNSON, Mod K-40, 1928, V. Haines,
 207 E Proctor, Carson City, Nevada
 JOHNSON- Mod K-40, 1928, R. Fiorini,
 1984 Kington, Pontiac, Michigan
 JOHNSON- Mod SE-50, 1930, Electric, P.
 Boudreau, 11 Dennison, Waltham, Mass
 JOHNSON- Mod K-50, 1930, J. Marx, 217
 S Mayhew Box 253, New Buffalo, Mich.
 JOHNSON- Mod A, 1924, A. Lumm Jr., 3997
 W Bancroft, Toledo, Ohio
 JOHNSON- Mod J-75, 1935, W. Miles, 277
 King George, Ottawa, Ontario, Canada
 JOHNSON- Mod 100, 1936, M. Garriga, 611
 Murray, Gilroy, California
 JOHNSON- Mod PO, J. Adams, Rt 74 Box
 19, Maykoto, Minnesota
 JOHNSON- Mod 100, 1936, S. Gerrish,
 West Peru, Maine
 JOHNSON- Mod A-45, 1929, C. Chapulis
 7252 W Pratt, Chicago, Illinois
 JOHNSON- Mod P-75, 1935, B. Hodgins
 199 Loach, Sudbury, Ontario, Canada
 JOHNSON- Mod K-35, 1927, B. Crery,
 1614 4th, Jackson, Michigan
 JOHNSON, Mod KA-37, 1937, D. La Rue,
 814 S Summit, El Dorado, Kansas

The Old Reliable DIAMOND JO LINE Steamers.

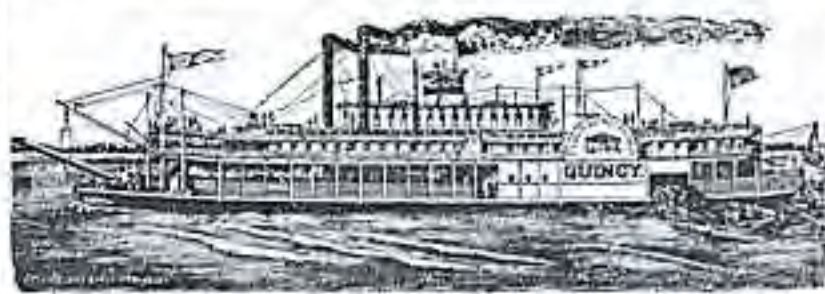

The Upper Mississippi Packet Line. Established 1867.
We take pleasure in announcing that during the season of navigation we will continue to operate a line of fine passenger packets between

ST. LOUIS AND ST. PAUL.

To those who know the history of the Diamond Jo Line Steamers for the past thirty years, it is hardly necessary to say that we will keep to the front and continue to merit the approval which our patrons have so kindly given us in the past. To those whose attention has never been called to the attractions of the UPPER MISSISSIPPI RIVER, we say, "give us a trial." We will do our best to please you, and can guarantee that you will be amply repaid for your time and money by the benefit derived from A TRIP ON THE GREAT FATHER OF WATERS. Timetables, rate and route lists and any desired information regarding our line and route, sent on application to general passenger agent or to any of our local agents.

Excursion and Tourist Tickets to all Points of Interest Below.
Get our rates before purchasing tickets by any other route.
J. P. LUSK, Gen. Pass. Agent, St. Louis, Mo.
HARRY CLARK, Agent, St. Paul, Minn.
St. Paul Office and Dock, Foot of Sibley Street.

NEPTUNE



OUTBOARD MOTORS

EASIER TO ROW

Write today for free catalogue
15 foot boat, crated \$29

ABSOLUTELY SAFE



Mullins Unsinkable Steel Pleasure Boats

Boats of steel. Properly constructed. An original and new design. Guaranteed. No rust. No rot. No decay. No damage. No loss. No expense. No trouble. No worry. No danger. No loss of life. No loss of property. No loss of time. No loss of money. No loss of pleasure. No loss of health. No loss of anything else. No loss of anything at all.
W. H. MULLINS, 662 Depot Street, Salem, Ohio



Prouty Hand Motor, that gives far better results than ours. Easily installed in most boats. Safe and a surprising developer of physical strength. Send for descriptive circular. **Agents Wanted** for our different specialties.

PROUTY MFG. CO., 35 Oliver St., Boston, Mass.

Manufacturers of BOATS, SHAPING, IMPROVED STUFFING BOXES and PROPELLERS for Gasoline Motors, THE PERFECT RUBBER HANGER, and GIANT LIGHT INCREASES.

CHAMPION
OUTBOARD MOTOR
TRADE MARK REG.
Manufactured by
CHAMPION MOTORS COMPANY
Minneapolis, Minn.

GRAY

2 1/2 H.P. Complete Outfit \$65
and guaranteed in develop more than 3 1/2 H.P. In fact, it is as powerful as most 4 H.P. engines.

WIZARD
Outboard
MOTORS
Western Auto Stores
A NATIONAL INSTITUTION

JOIN The Antique Outboard Motor Club Inc.

MEMBERSHIP INFORMATION

Name _____ Date _____

Address _____ Telephone _____

City _____ State _____ Zip _____

Number of pre-1942 motors collected _____

Check the way(s) that you most enjoy Antique Outboording:

Collecting motors

Running motors

Restoring motors

Collecting information

Mail this application and \$5.00 to:

THE ANTIQUE OUTBOARD MOTOR CLUB
1107 Pueblo Drive
Richardson, Texas 75080

AOMCI New Members

- Elliot Brumbaugh, 4309 Elm St., Chevy Chase, Md., 20015
Robert M. Bordell, III, 2 N. Adgers Warf, Charleston, S.C. 29401
Donald E. Callar, Box 3006, Alexandria, Va. 22302
Carl L. Castle, 4655 Elmhurst Dr., San Jose, Calif. 95129
Walter Wm. Cave, 1229 W. 48th St., Ashtabula, Ohio 44004
Orville B. Coomer, Jr., 3912 Massie Ave., Louisville, Ky. 40207
Harold F. Culp, 170 N.E. 158th St., Miami, Fla., 33162
Claude Foss, 298 Indian River Dr., Palm Bay, Fla. 32901
Hovey Harmon, Box 185, Dexter, Maine 04930
Richard Von Heitman, 3256 Midway Dr., San Diego, Calif. 92110
Donald E. Hinds, 329 Walnut St., Stoughton, Mass. 02072
William L. Horst, 2422 N. Ft. Thomas Ave., Ft. Thomas,
Ky. 41075
- Oliver N. Iverson, 6401 Wilryan Ave. S., Minneapolis, Minn. 55435
Robert E. Jacobs, 1413 Birchlawn Pl., Ottawa, Ill.
Jay Bennett Jans, 13th Co., U.S. Military Academy, Annapolis, Md.
Robert Jevariam, 366 Franconia, San Francisco, Calif. 94110
Dave Johnson, 110 W. 27th St., Minneapolis, Minn. 55408
Wesley Lively, Blairstown, Iowa 52209
Nix Marine, 10418 - 105th Ave., Edmonton 17, Alberta, Canada
Mike Molchan, Box 146, Fort Wainwright, Alaska, 99703
Anthony L. Pringle, Comfair West Pac, F.P.O., Seattle, Wash. 98767
Norris J. Rushing, Box 218, Gonzales, La. 70737
Gordon R. Stanley, Box 1118, Rockport, Texas 78382
Perry A. Stanley, 104 High St., Wallingford, Conn. 06492
Frank Stock, 1460 Forest Ave., Portland, Maine 04103
Warner J. Turner, 174 Wickert Dr., Rt. #4, West Bend, Wis.
53095
- W. H. Venturella, 275 Viewland Pl., San Pedro, Calif. 90731



**FULL
COLOR
AUTHENTIC
LOOKING**

DECALS

AVAILABLE NOW
4 piece set for Evinrude Models
A and B, 1911-1928
\$4.50 per set

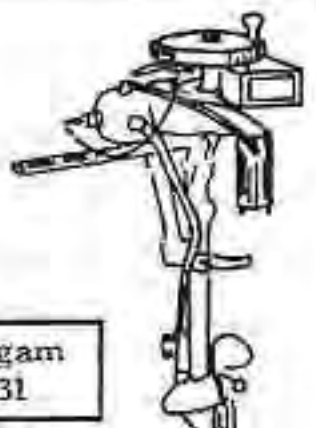

Send check or money order to R. Brautigam
2316 W. 110th St. Minneapolis, Minn 55431

COMING: DECALS FOR ELTO, EVINRUDE AND JOHNSON

The Antique Outboard Motor Club Inc.

Published, 2316 W, 110th St
Minneapolis, Minn 55431

Home Office, 1107 Pueblo
Richardson, Texas 75080

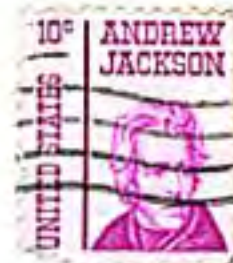

PRINTED MATTER - NO COMMERCIAL VALUE



THE SCENE AT LAKE HOPATCONG, NEW JERSEY