

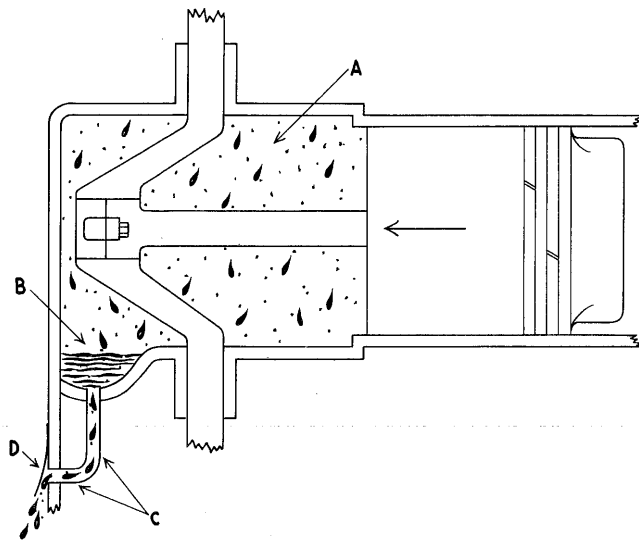

**CRANKCASE BLEEDER
BASIC ALL MODELS**

Schematic drawings shown here are to illustrate crankcase bleeder action which becomes active with slow speed operation as when idling or trolling.

Maximum vaporization of the fuel mixture (after leaving the carburetor) is dependent upon degree of crankcase and manifold turbulence or "agitation" created by higher air velocities and the revolving crankshaft and movement of the piston. Constant or high velocity action is required to maintain suspension of all fuel particles for complete combustion and best performance.



During periods of "slow" running, velocity or turbulence in the crankcase correspondingly diminishes to result in the heavier fuel particles "settling out" or condensing — characteristic of petroleum fuels. Eventually an accumulation of liquid fuel "pools" to slosh around in the crankcase and as such, contributes to faulty slow and interme-

diated speed operation, excessive carbon accumulation "smoky" exhaust and evidence of "choking" when accelerating unless means are provided for its dissipation.

On downward stroke of the piston, pressure is built up in the crankcase — bearing down on surface of the condensed pool "B" causes bleeder valve (flapper) "D" to be lifted from its seat, thus permitting a portion of the condensed fuel escaping.

On the succeeding upward stroke, pressure diminishes and crankcase suction occurs when the bleeder valve "springs" back on its seat. However, crankcase pressure recurs on the following downward stroke to further clear the crankcase of condensed fuel which is eventually discharged into the exhaust system to account for the "oil slick" frequently observed as trailing on surface of the water when running at slow speed.

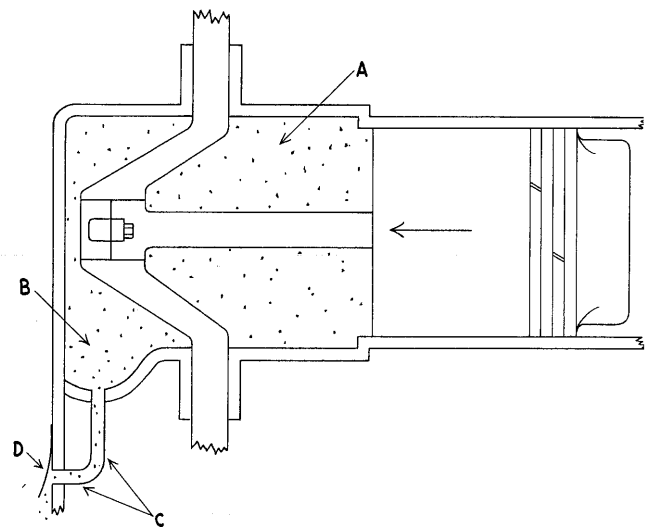

With increasing of motor speed (RPM's) turbulence or velocity in the crankcase is progressively increased to maintain suspension of a greater portion of the fuel particles (less condensation or settling out) — subsequently less bleeding of condensed fuel. The heavier fuel particles still continue to condense out but only to a point of where rate of turbulence (governed by motor speed) in the crankcase is sufficient to hold all particles of the fuel mixture in suspension at which time "bleeding" is reduced to practically nil, as sketch above indicates.

The bleeder valve arrangement as described functions at all times regardless and throughout entire speed range of the motor; when not bleeding liquid or condensed fuel (high speed) crankcase pressure loss (if any) is of little significance due to the extremely small bleeding orifice and rate of motor speed.

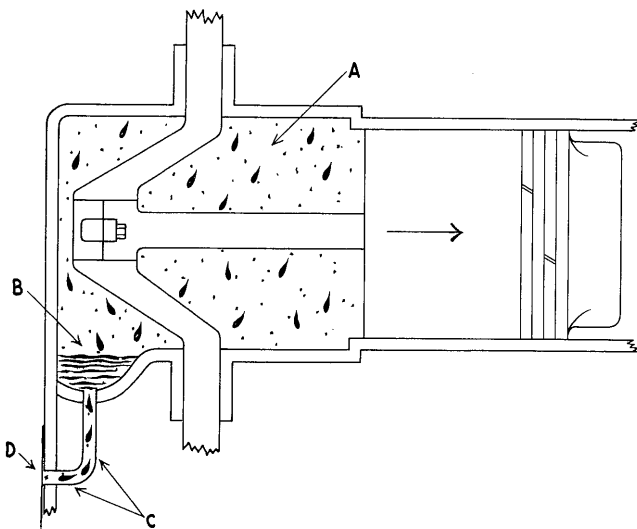



Ordinarily the bleeder system requires little or no attention except that when conducting major repairs, it is advisable to remove the bleeder valve and as precautionary measure "blow out" the bleeder channels or drains with high pressure air to insure against possible clogging later on. Should there be evidence of gum or varnishing within the crankcase, run a fine wire through the channels,

being careful not to injure the bleeder valve seat. Make sure at this time that the bleeder valve comes to rest squarely on its seat when reassembling and that the supporting back strip is properly installed to permit function of the bleeder valve segments. Note—The Model CD bleeds only from the intake manifold chambers — top and bottom.

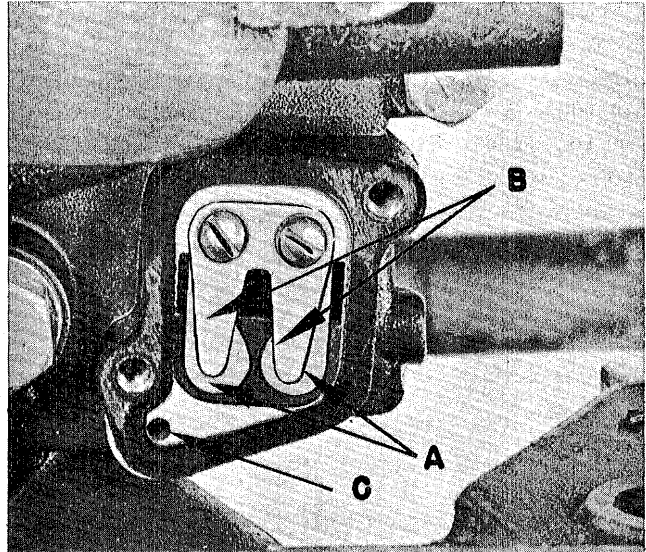
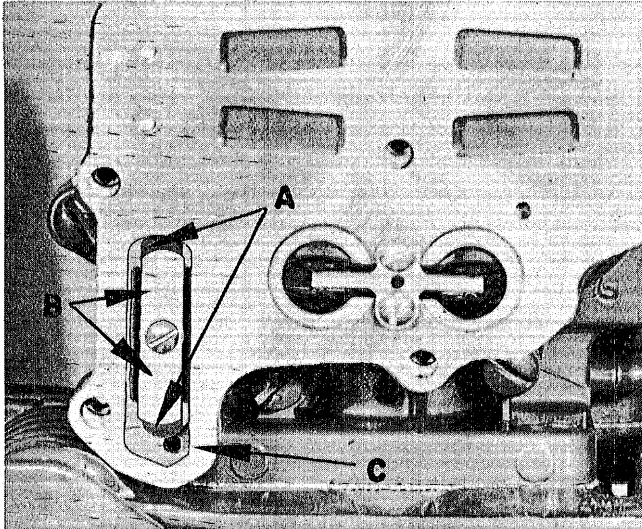

Illustrating arrangement of bleeder assembly as employed in construction of all models, except QD-11 through 14, RD and RX Series. "A" — bleeder valve; "B" — back strip to guide movement of bleeder valve; "C" — bleeder discharge.

Showing arrangement of bleeder valve assembly as installed on the Model RD and QD previous to QD-15. "A"—bleeder valve segments; "B"—back strips to guide action of bleeder valves; "C"—bleeder discharge.

NOTES

Series of horizontal lines for taking notes.